

---

# Model 600 Installation Instructions & Owners Manual

---

## Automatic Door Operator

- Center Hung
- Flush

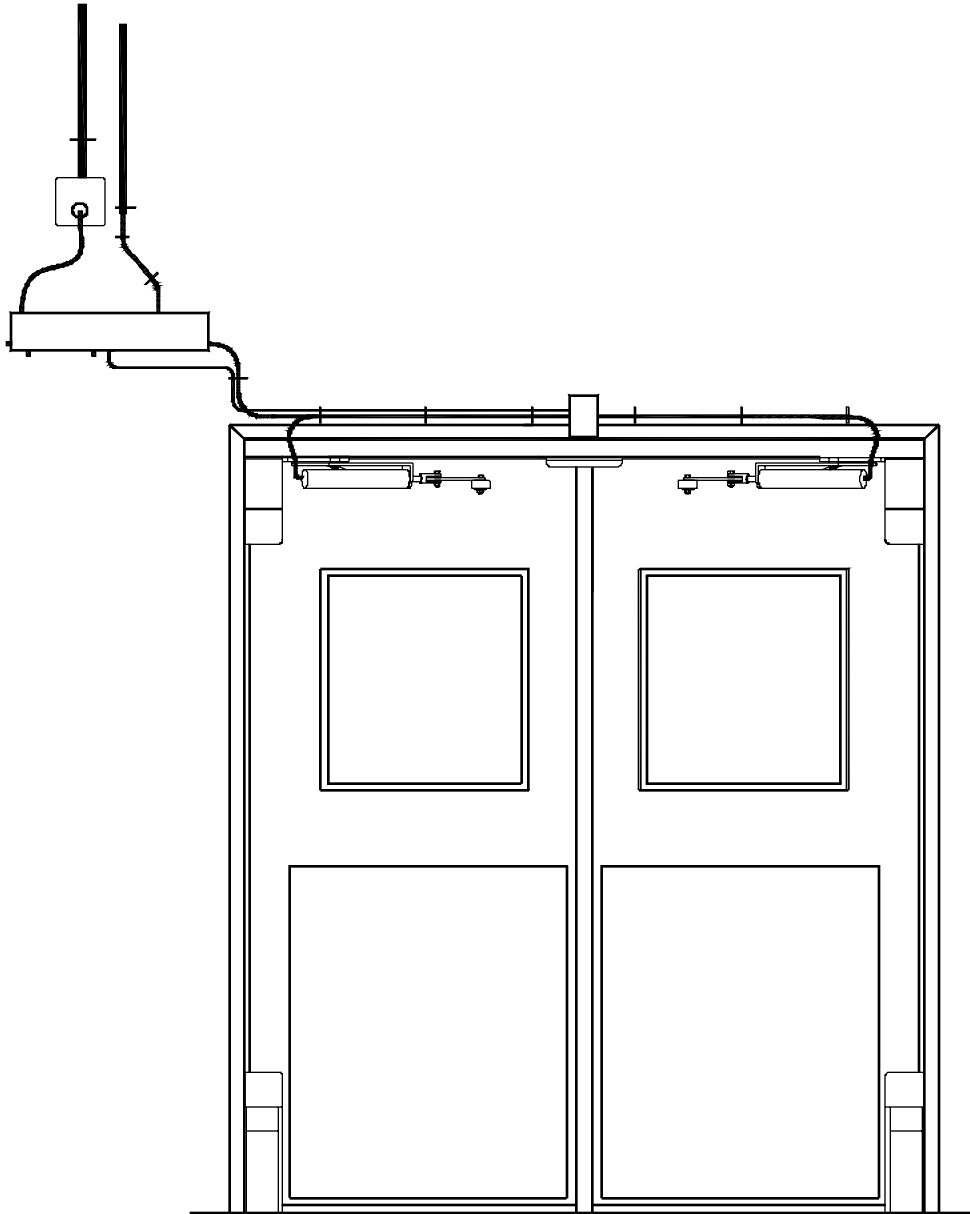

**CHASE Industries, Inc.**

10021 Commerce Park Drive • Cincinnati, Ohio 45246  
(513) 860-5565 • (800) 543-4455 • Fax (800) 245-7045

Technical Support (800) 305-6736

2/1/11

---

P/N 15099.00

---

# Contents

---

2

	Page
Section 1	Product Description 3 - 4
Section 2	Safety - READ BEFORE OPERATING OPENERS! 5
Section 3	Installation 8 - 24
	Cam-Rise Center Hung Doors -New Construction - 8
	Door Mount
	Header Mount
	Cam-Rise Center Hung Doors -Retrofit - 12
	Flush Infitting Doors - 20
	Door Mount
	Header Mount
Section 4	Operation 25
Section 5	Maintenance 26
Section 6	Troubleshooting 27 - 28
Section 7	Parts List & Exploded View 29
Section 8	Electrical Wiring & Circuit Board User's Manual 30 - 38
Section 9	Options 39 - 44
Section 10	Instruction Sheets / Drawings 45 - 62
	Doorstop Installation - Head Mounted - Center Hung Doors Only
	Floor Mounted - All Doors
	Basic Component Orientation & Hole Patterns
	Closer Shim Tube Installation - Center Hung Doors
	LCN 4011 Closer Component Installation
	No-Rise Conversion Kit Installation Instructions
	Filler Tube Sizing for Cam-Lift to No-Rise Hinge Conversion
	Double Acting (Center Hung) Doors: Jamb & Head Construction
	Details 1, 2, 3, & 4
	Cam-Lift Double Acting Doors Converted to No-Rise Single
	Action with Opener

---

---

## Section 1 - Model 600 Description

---

### **Application**

The 600 series door operator is a surface mounted pneumatic door opener. It is used for swing doors in Industrial, Institutional and Commercial applications. It is compatible with virtually all types of interior and exterior doors. Door panels from 2'-6" to 5'-0" wide and weighing up to 600 pounds can be accommodated. One way, two way and two way bi-parting traffic patterns can be used by varying combinations of activators and orientations of actuators. Simultaneous operation of double doors is standard.

### **Description**

The 600 series operator applies opening force to the door header by a pneumatic cylinder, actuator arm and a rubber wheel. There are only three minimally wearing bearing points for long life and there are no gears, clutches or motors required. The operator is not attached to the door so it can be operated manually with complete means of egress at any time, without any harm to the opener mechanism. A standard pull side door closer provides the closing portion of the cycle. Automatic operation is obtained through a wide number of activation devices. Because of the operator Ultra-Force™ bracket configuration and pneumatic system there is little risk of damage if the doors are activated and then struck with a load, or activated while the doors are locked or blocked in the open or closed positions.

### **Operation**

Automatic door operation is accomplished when the open or initiate command is transmitted from the activation device to the control enclosure. A wide variety of devices can be used to activate the doors including: wall switches, floor mats, motion or proximity sensors, touchless switches, infrared beams, remote radio control, or any device that switches using dry contacts. A microprocessor based control board controls the hold open time and functionality of the doors. Hold open times can be set from 1-99 seconds by means of the control board, and opening times can be adjusted from 1.5 to 5 seconds by changing air regulator pressure and air flow controls.

### **Mounting**

The 600 series can be easily mounted to any conventional door frame header and the face of the door. Reinforcement of hollow metal jams may be required. Special reinforcing plates are available. Installation and service should be conducted by qualified personnel. Technical support is available by calling the factory at **1-800-305-6736**.

### **Control Enclosure**

The control enclosure is microprocessor based to insure maximum reliability and flexibility for the end user. The system has been designed to be easy to set up and operate. The control unit is designed to be connected to a constant power source of 110VAC 60HZ or 230VAC 50HZ, which powers the control enclosure and a wide variety of activation devices with 24VAC power. The control enclosure can be mounted up to 25 feet away from the operators (consult factory for greater distances). The only connection between the control enclosure and the operators is two flexible 1/4" diameter air lines. Air supply to the control enclosure is accomplished through a single 1/4" or 3/8" air line.

### **Security**

Connecting to security devices such as electric strikes, electromagnetic locks, card readers, keyed switches, time locks and push button key pads is easily accomplished. Consult factory to determine appropriate control panel configuration.

---

# Section 1 - Product Description

Center Hung Mounting Shown

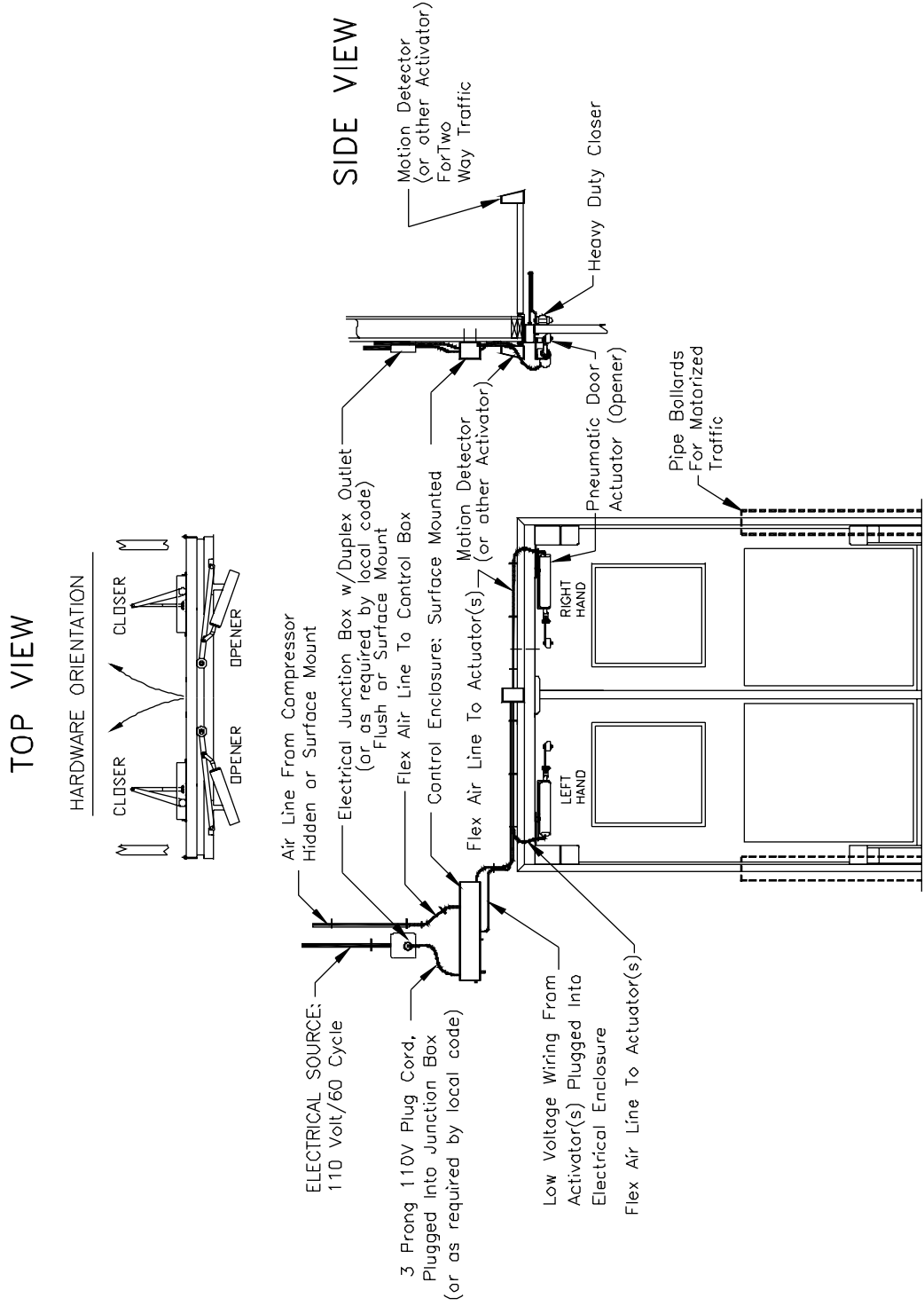

INCLUDES: (1) CONTROL ENCLOSURE, (2) ACTUATORS, AND (2) CLOSERS COMPONENT, AIR LINE PLUMBING AND ELECTRICAL WIRING LAYOUT

FRONT VIEW

DD-9010Ap

## Section 2 – Safety

### - WARNING -

Read these safety practices before installing, operating or servicing the door opener. Failure to follow these safety practices could result in property damage, serious bodily injury or death.

**READ AND UNDERSTAND ALL OPERATING INSTRUCTIONS IN THIS MANUAL BEFORE OPERATING THE DOOR OPENER.** If you do not understand the instructions, ask your qualified supervisor to teach you how to use the door opener.

**IMPORTANT:** Doors must have vision panels in each door panel and/or be in accordance with all applicable OSHA or other governing rules and regulations.

1. Do not operate the door opener while under the influence of drugs or alcohol.
2. Do not use the door opener if it or the door appears in any way to be broken or not operating properly. Advise your supervisor at once.
3. Stay clear of the door and door opener while moving.
4. Keep all body parts including hands, feet, and head clear of door and door opener at all times.
5. Do not operate the door opener with equipment, material, people or any other object in the door or openers operational path.
6. Disconnect power before performing any electrical, mechanical or air supply service, cleaning or other maintenance on the door or door opener. OSHA requires power and air supply to be properly tagged and locked out during all maintenance or service of the equipment. With the power supply disconnected, always verify using a volt meter.
7. All electrical, mechanical or air supply troubleshooting or service must be completed by a qualified personnel or service person and must meet all applicable local, state, federal, international and any other governing agency codes.
8. When it is necessary to service the control box with power on, **USE EXTREME CAUTION.** Do not place any fingers or un-insulated tools inside the control box. Touching wires or other parts inside the enclosure may cause electrical shock, serious injury or death.
9. It is your responsibility to keep all warning labels and instructional manuals legible, intact and kept with the door opener. Replacement labels and manuals are available from Erich Industries, Inc.
10. Prior to putting the door opener into operation the user must have a safety training meeting with all personnel and users to instruct them on proper operation and all applicable safety procedures.
11. If you have any questions contact your supervisor or Erich Industries, Inc.
12. Failure to operate the door opener as intended, as described, or heed any warning may result in equipment damage, property damage, serious bodily injury or even death.

## "KWIK-OP" Opener/Closer System

①

### 3 MOUNTING METHODS FOR HEADER INSTALLATION

#### STANDARD MOUNTING METHOD

RECOMMENDED FOR MOST APPLICATIONS. UNIVERSAL – CAN BE MOUNTED ON VIRTUALLY ALL TYPES OF SWING DOORS. IDEAL FOR NEW CONSTRUCTION AND RETRO-FITS ON EXISTING SWING DOORS.

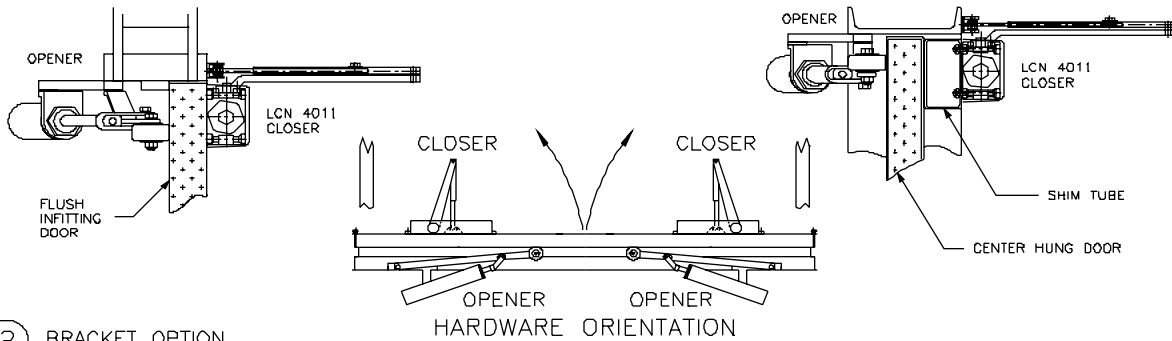

②

#### BRACKET OPTION

#### HINGE SIDE COMPONENT MOUNTING

USED ONLY ON FLUSH INFITTING TYPE DOORS. IDEAL FOR CLEAN ROOMS AND IN-SWINGING SECURITY DOORS. THIS METHOD ALLOWS THE OPENER AND CLOSER COMPONENTS TO BE MOUNTED ON THE BACK (SWING) SIDE OF THE DOORS USING THE FACTORY SUPPLIED MOUNTING BRACKET, SO WHEN THE DOORS ARE FULLY OPENED, THE COMPLETE OPENING IS AVAILABLE FOR USE.

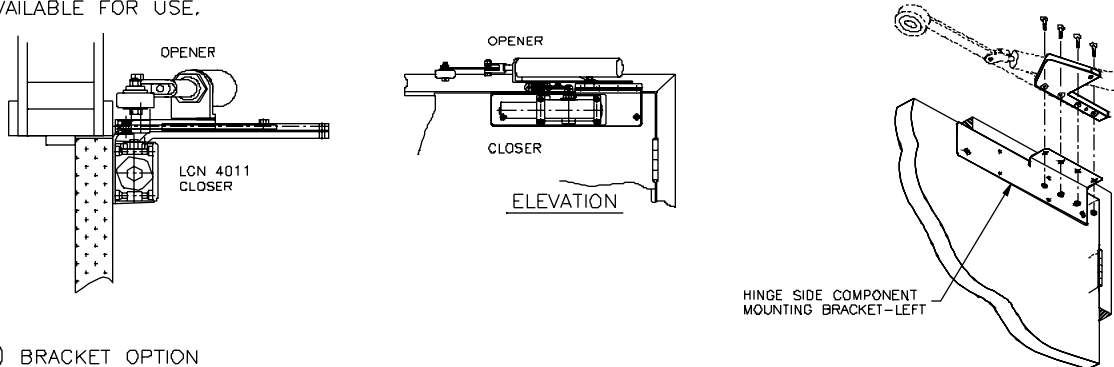

③

#### BRACKET OPTION

#### PUSH SIDE COMPONENT MOUNTING

ALLOWS ALL COMPONENTS TO BE MOUNTED TO THE HEAD ON THE "PUSH SIDE" WITH FACTORY SUPPLIED MOUNTING BRACKET. CAN BE USED WITH FLUSH INFITTING AND CENTER HUNG DOORS. IDEAL FOR APPLICATIONS WHERE SWING SIDE OF DOOR HAS INSUFFICIENT CLEARANCE FOR CLOSER PROJECTION, AND FOR OUTSWINGING SECURITY DOORS. NOT RECOMMENDED FOR OPENING HEIGHTS OF LESS THAN 7'-6" OR WHERE HIGH LOADS PASS THROUGH THE OPENING.

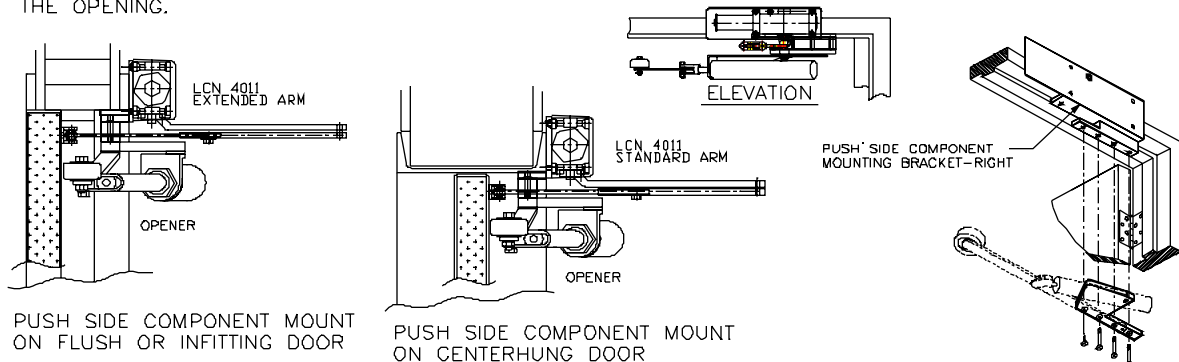

**Center Hung, New Construction**

---

# Section 3A - Center Hung, New Construction

## OPENER / CLOSER INSTALLATION INSTRUCTIONS CAM-RISE CENTER HUNG DOORS - NEW CONSTRUCTION

- STEP 1: Install the doors according to manufacturer's instructions.  
DOORS MUST SWING FREELY (GASKETS MUST NOT DRAG ON FLOOR OR HEADER)  
OR OPERATOR WILL NOT FUNCTION PROPERLY.  
IMPORTANT NOTE: Hinge centerline must be 3" from closer side of jamb.

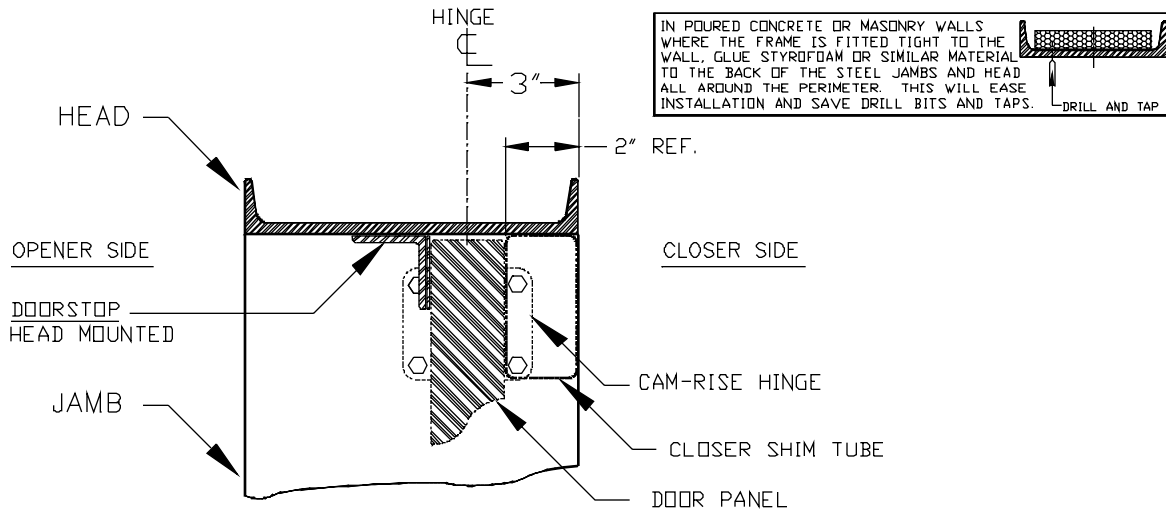

- STEP 2: Install HEAD MOUNTED DOOR STOP per drawing instruction sheet.

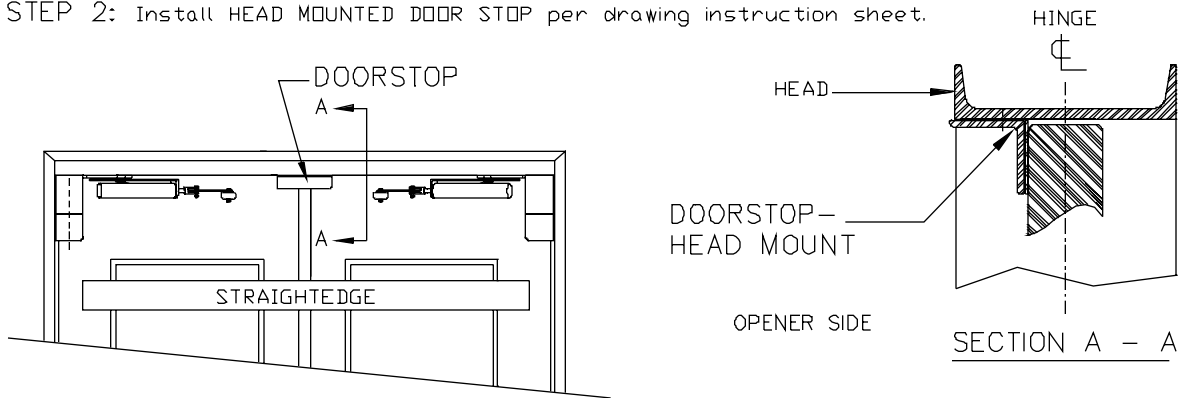

- STEP 3: Install FLOOR MOUNTED DOOR STOPS (IF USED) per instruction sheet.

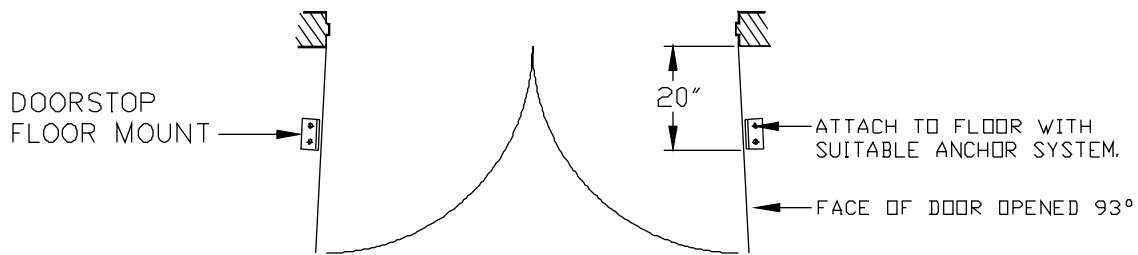

# Section 3A - Center Hung, New Construction

## OPENER / CLOSER INSTALLATION INSTRUCTIONS CAM-RISE CENTER HUNG DOORS – NEW CONSTRUCTION

STEP 4: Drill and tap holes for T-BRACKET using template 15043.00.  
NOTE: T-BRACKET must be a minimum of 1" from face of door in closed position.  
Refer to Basic Component Orientation & Hole Pattern drawing for location dimensions.

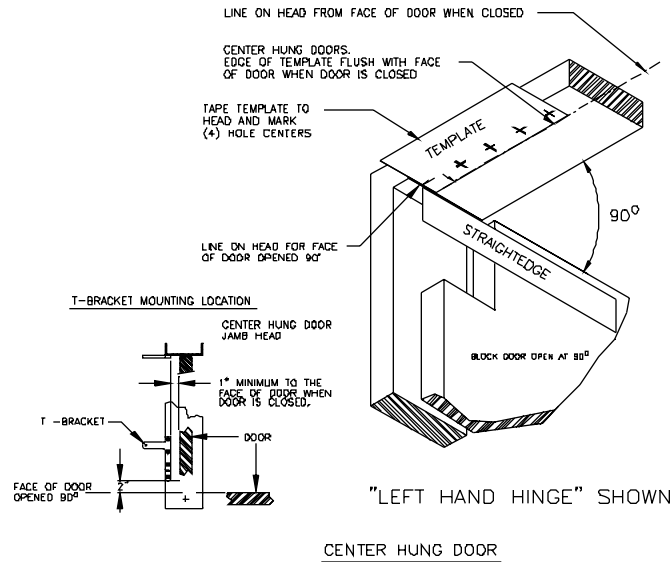
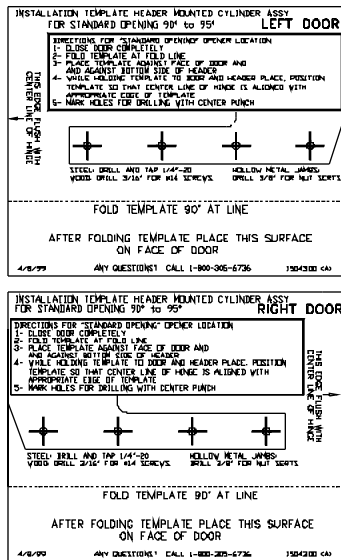

STEP 5: Install the T-BRACKET and ACTUATING ARM using the stainless steel screws provided.

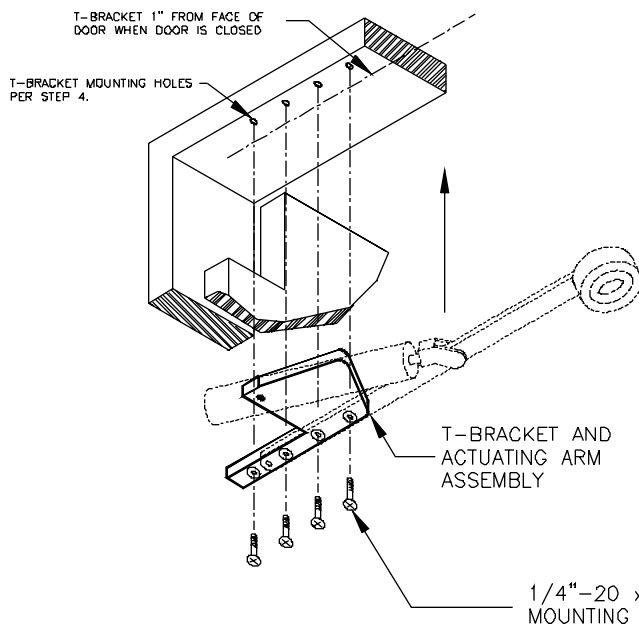

### INSTALLATION PROCEDURE

A. Install the T-BRACKET and ACTUATING ARM assembly using the (4) 1/4"-20x7/8" Flat Head Phillips Machine Screws.  
NOTE: Left hand and Right hand assemblies are marked "L" or "R" on the top of the T-BRACKET.

B. Cycle the actuator manually through it's complete range of motion to insure that all components are attached properly and do not interfere with any other components.  
Adjust if necessary.

# Section 3A - Center Hung, New Construction

## OPENER / CLOSER INSTALLATION INSTRUCTIONS CAM-RISE CENTER HUNG DOORS – NEW CONSTRUCTION

STEP 6: Install SHIM TUBE and CLOSER using template 15044.00.

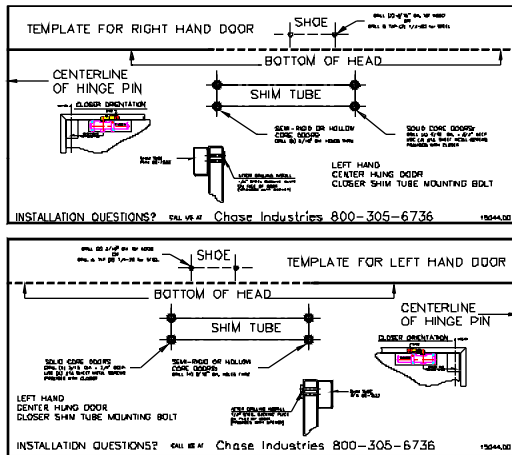

### SHIM TUBE MOUNTING

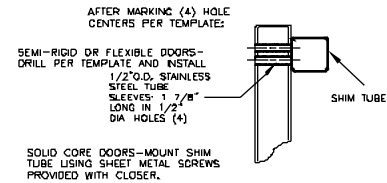

### CLOSER ORIENTATION

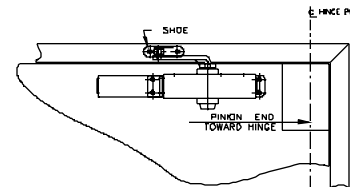

STEP 7: Install CONTROL ENCLOSURE to wall per template. Mount with anchors and screws provided.

CONTROL ENCLOSURE TO BE MOUNTED AT LEAST 6" ABOVE TOP OF OPENING 6" MIN.

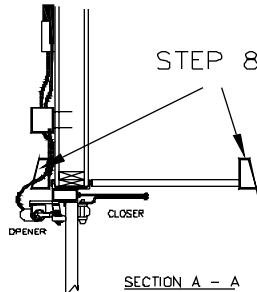
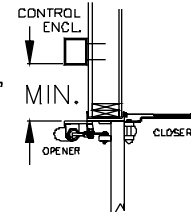

STEP 8: Install ACTIVATING DEVICE (motion detector, etc.) according to manufacturer's instructions using the (4) 8-32 x 1/4" Hex Washer Thread Forming Screws. Drill size #25.

STEP 9: Connect CONTROL ENCLOSURE to air supply and electrical supply, making sure ON/OFF switch is OFF (white showing).

NOTE: Purge or blow out air lines prior to connecting air supply to control enclosure. WARRANTY MAY BE VOIDED IF THIS STEP IS OMITTED.

STEP 11: Connect ACTIVATING DEVICE(S) to CONTROL ENCLOSURE by inserting the plug into any of the 5 MOLEX receptacles located inside the control enclosure. Pass the open end of cable(s) through one or both of the strain relief connectors located on the bottom of the control enclosure and tighten. Connect cable to actuating device per the instructions attached to the cable.

NOTE: When longer runs of cables are required, splice the color coded wires to the pigtail leaving ALL connections inside the control enclosure.

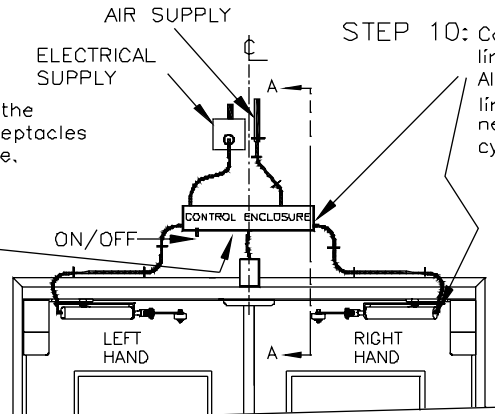

STEP 10: Connect 1/4" flexible air lines from control box to AIR CYLINDERS by inserting lines into the quick disconnect fittings on box and cylinders.

# Section 3A - Center Hung, New Construction

## OPENER / CLOSER INSTALLATION INSTRUCTIONS CAM-RISE CENTER HUNG DOORS – NEW CONSTRUCTION

STEP 12: Turn on control enclosure and test unit, adjust closer as necessary for smooth opening, backcheck cushioning, and latch check.

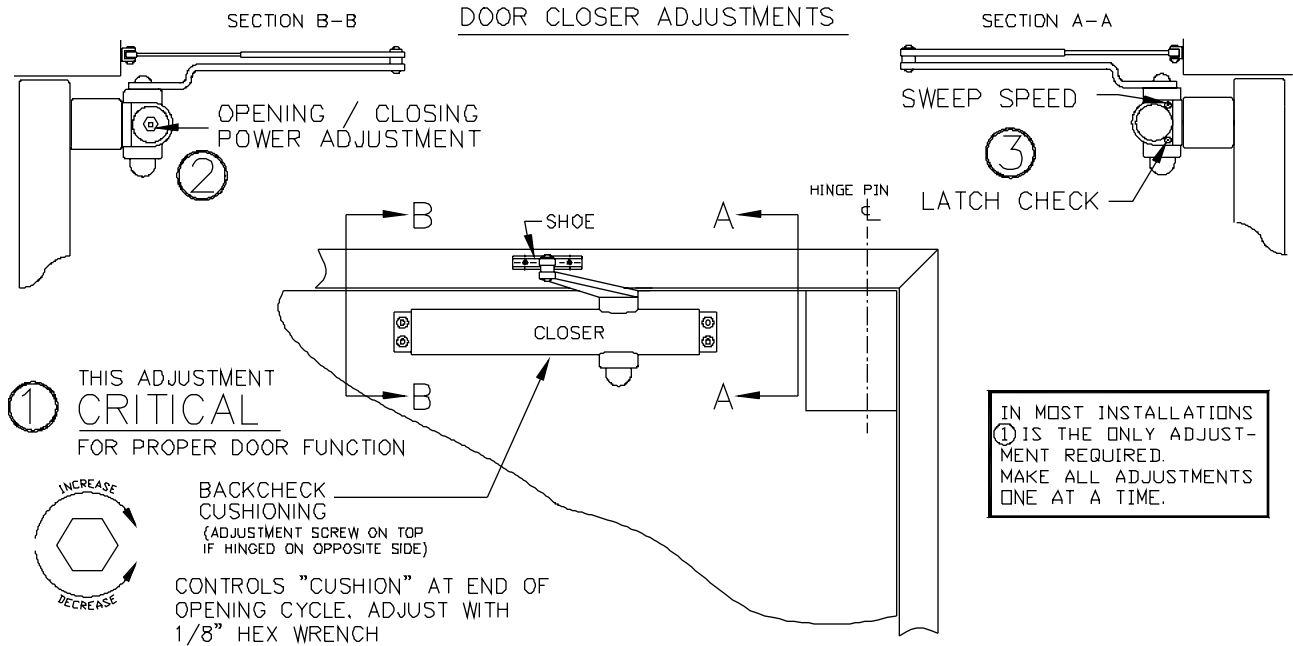

STEP 13: Adjust opening speed with the Air Pressure Regulator. Pull knob "out" to adjust, then push knob "in" to lock in adjustment. Factory setting is 45 PSI.

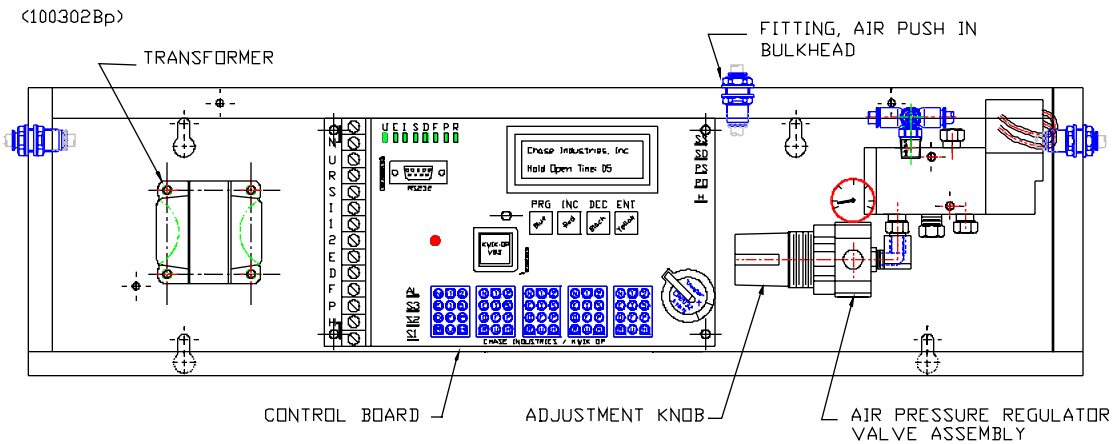

STEP 14: Adjust activating device according to manufacturer's instructions, specifications, or to owner's preference.

STEP 15: For future use, these installation instructions should be left with the proper authority on site.

**Center Hung, Retrofit**

---

# Section 3B - Center Hung, Retrofit

## Cam-Rise Center Hung Doors - Retrofit

**STEP 1:** Convert the existing cam-rise hinge system with the NO-RISE Conversion Kit per instruction sheet in the Instruction Sheets/Drawings Section of this manual. DOORS MUST SWING FREELY OR OPERATOR WILL NOT FUNCTION PROPERLY. Establish a 1/8" to 1/4" gap between the top of the door panel and the head by one of the 3 methods shown below.

**RAISE DOOR/HINGES**

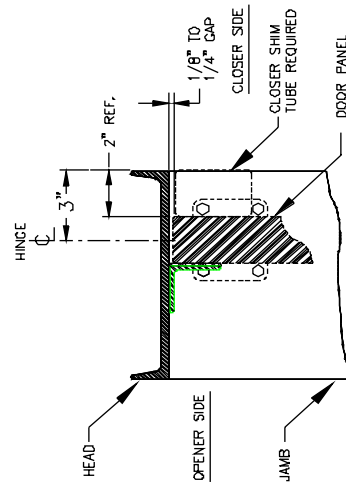

Raise door panel or hinge system to establish the desired 1/8" to 1/4" gap between the top of door panel and head. Horizontal movement of hinge centerline to 3" dimension may be necessary. A CLOSER SHIM TUBE is required. An EXTENDED BOTTOM SWEEP may be required. See Instruction Sheets/Drawings Section for details.

**FILLER TUBE**

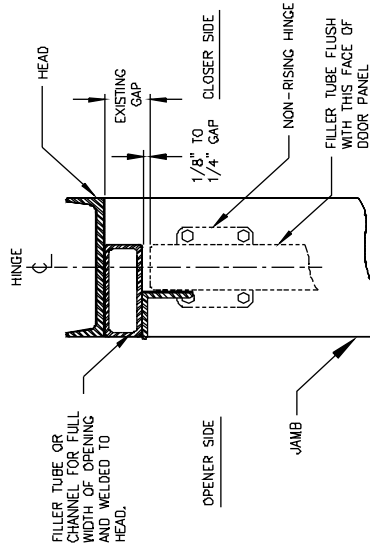

**FOR 7" -6" AND TALLER OPENINGS**

An appropriate sized steel tube or channel is welded to the head to achieve the desired 1/8" to 1/4" gap. NO movement of door panel or hinges is required. NO Closer Shim Tube is required. See Instruction Sheets/Drawings Section for details.

**STIFFENER CAP**

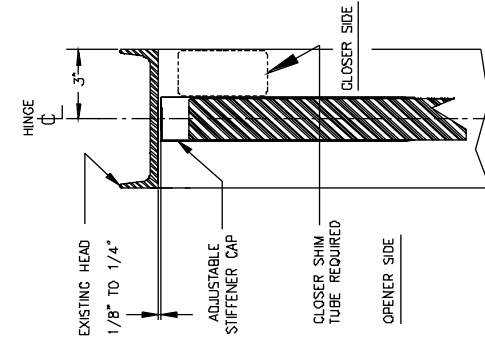

An ADJUSTABLE STIFFENER CAP is attached to the top of the door panel to establish the desired 1/8" to 1/4" gap. Horizontal movement of the hinge centerline may be necessary. A CLOSER SHIM TUBE is required. See Instruction Sheets/Drawings Section for details.

IN POURED CONCRETE OR MASONRY WALLS WHERE THE FRAME IS FITTED TIGHT TO THE WALL, GLUE STYROFOAM OR SIMILAR MATERIAL TO THE BACK OF THE STEEL JAMBS AND HEAD ALL AROUND THE PERIMETER. THIS WILL EASE INSTALLATION AND SAVE DRILL BITS AND TAPS.

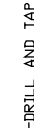

DRILL AND TAP

# Section 3B - Center Hung, Retrofit

STEP 2: Install HEAD MOUNTED DOOR STOP per details in Instruction Sheets/Drawings Section.

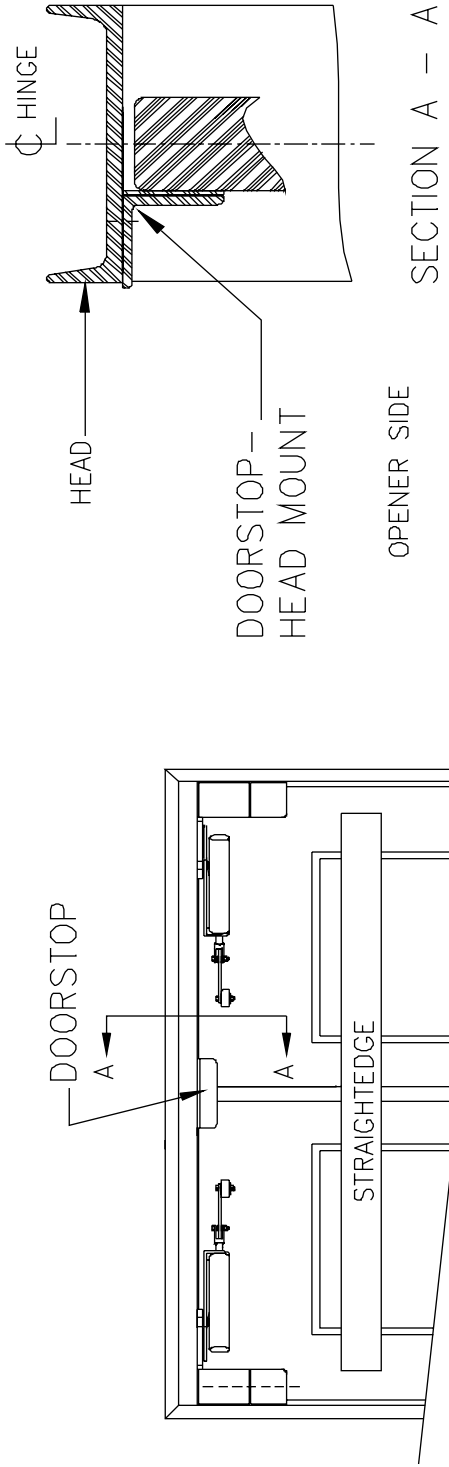

STEP 3: Install FLOOR MOUNTED DOOR STOPS (IF USED). See Instruction Sheets/Drawings Section for details.

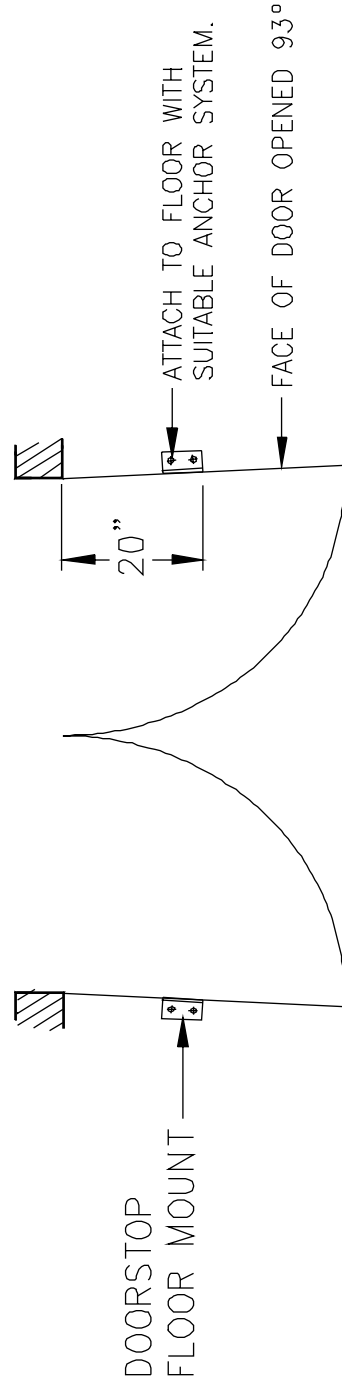

# Section 3B - Center Hung, Retrofit

## Cam-Rise Center Hung Doors - Retrofit

STEP 4: Drill and tap holes for T-BRACKET using template 15043.00 (A)

NOTE: T-BRACKET must be a minimum of 1" from face of door in closed position.

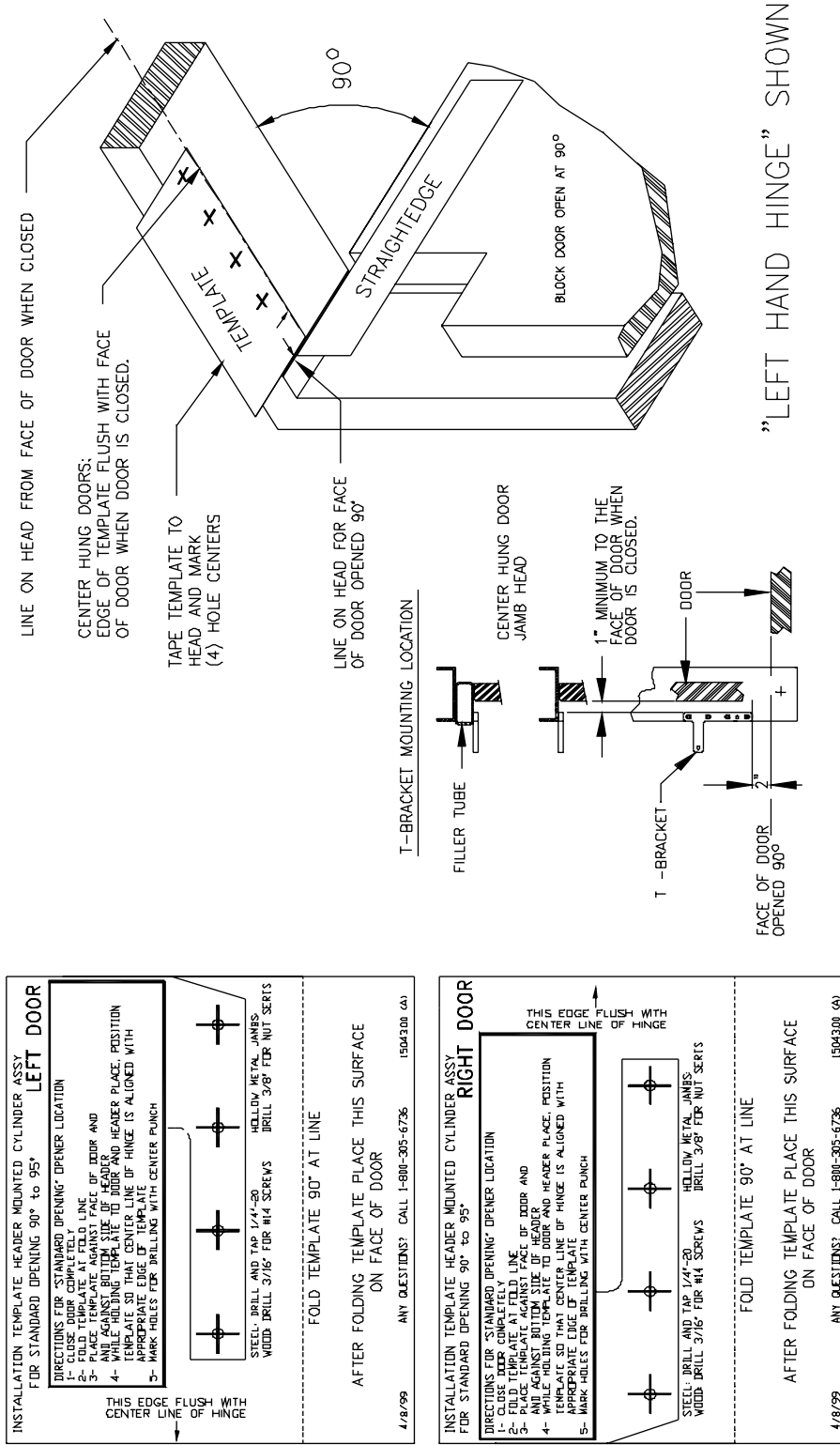

"LEFT HAND HINGE" SHOWN

STEP 5: Install the T-BRACKET and ACTUATING ARM using the stainless steel screws provided.

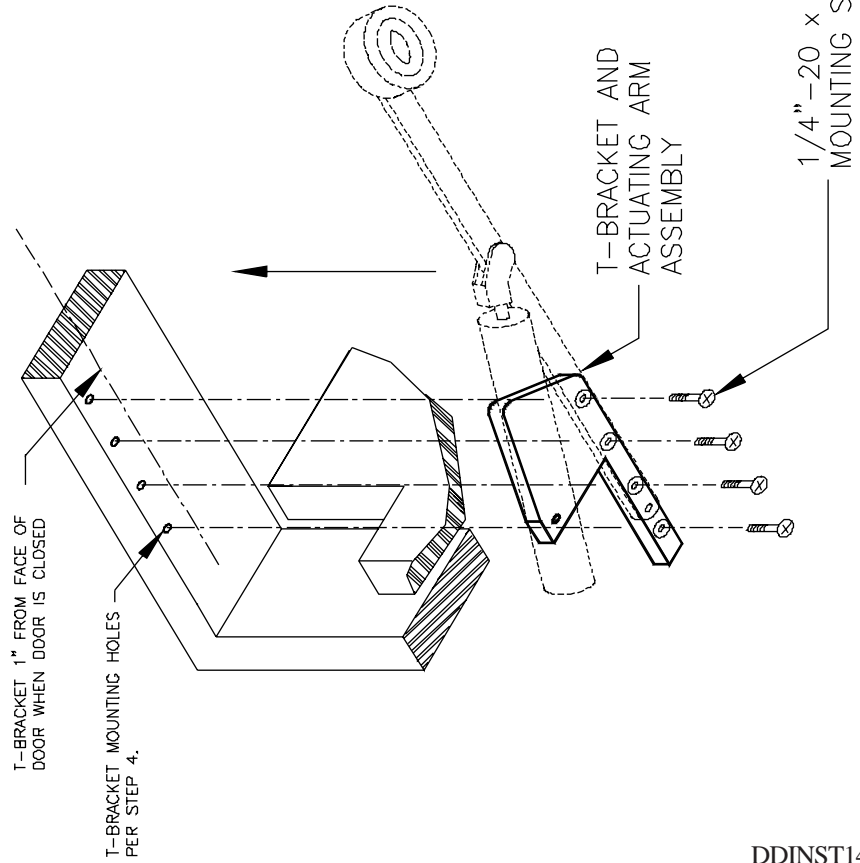

INSTALLATION PROCEDURE

- A. Install the T-BRACKET and ACTUATING ARM assembly using the (4) 1/4" - 20 x 7/8" Flat Head Phillips Machine Screws.  
NOTE: Left hand and Right hand assemblies are marked "L" or "R" on the top of the T-BRACKET.
- B. Cycle the actuator manually through its complete range of motion to insure that all components are attached properly and do not interfere with any other components.  
Adjust if necessary.

CAM-RISE CENTER HUNG DOORS - RETROFIT

STEP 6: Install SHIM TUBE and CLOSER using the SHIM TUBE INSTALL template. Refer to the BASIC COMPONENT ORIENTATION & HOLE PATTERN and the CLOSER SHIM TUBE drawings in the Instruction Sheets/Drawings Section for location dimensions.

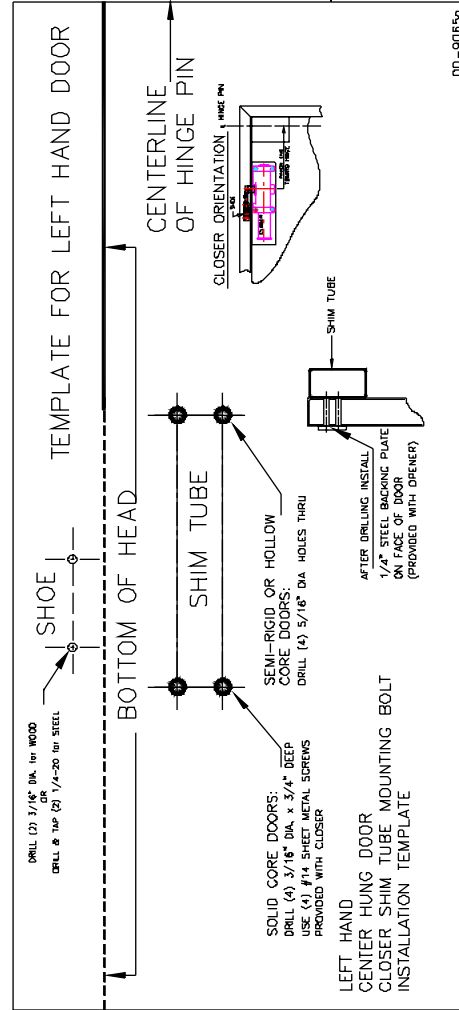

SHIM TUBE MOUNTING

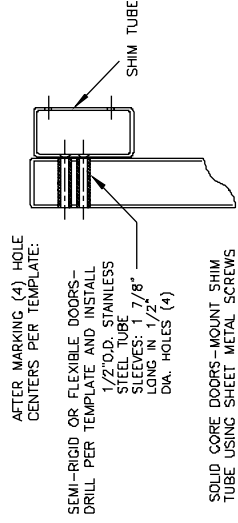

CLOSER ORIENTATION

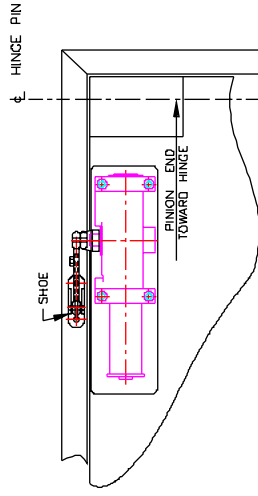

STEP 7: Install ELECTRICAL ENCLOSURE to wall per Control Box Mounting Template. Mount with anchors and screws provided.

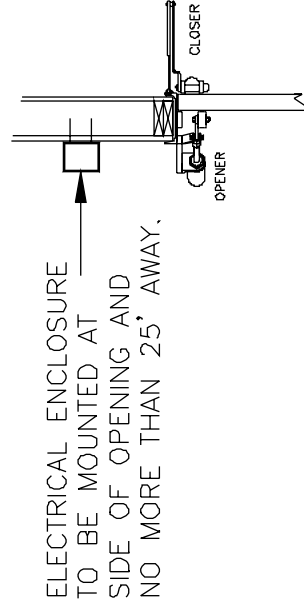

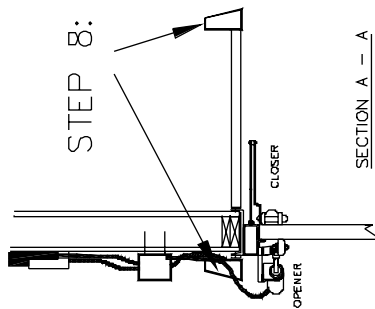

**STEP 8:** Install ACTIVATING DEVICE (motion detector, etc.) according to manufacturer's instructions using the (4) 8-32 x 1/4" Hex Washer Thread Forming Screws. Drill size #25.

**STEP 9:** Connect ELECTRICAL ENCLOSURE to air supply and electrical supply, making sure ON/OFF switch is OFF (white showing).  
 NOTE: Purge or blow out air lines prior to connecting air supply to electrical enclosure. WARRANTY MAY BE VOIDED IF THIS STEP IS OMITTED.

SECTION A - A

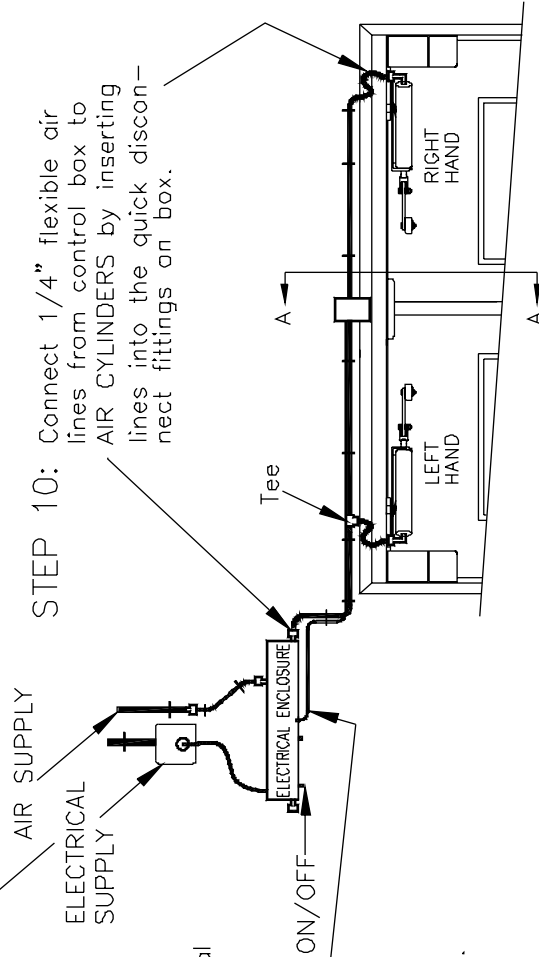

**STEP 10:** Connect 1/4" flexible air lines from control box to AIR CYLINDERS by inserting lines into the quick disconnect fittings on box.

**STEP 11:** Connect ACTIVATING DEVICE(S) to ELECTRICAL ENCLOSURE by inserting the plug into any of the 5 MOLEX receptacles located inside the electrical enclosure. Pass the open end of the cable(s) through one or both of the strain relief connectors located on the bottom of the electrical enclosure and tighten. Connect cable to actuating device per the instructions attached to the cable or per electrical wiring diagram in the instruction Sheet/Drawings Section.

NOTE: When longer runs of cables are required, splice the color coded wires to the pigtail leaving ALL connections inside the control box.

DWG. NO. DDINST20

REV. 6/15/98

## CAM-RISE CENTER HUNG DOORS

STEP 12: Power Control Enclosure and test unit. Adjust closer as necessary for smooth opening, backcheck cushioning, and latch check.

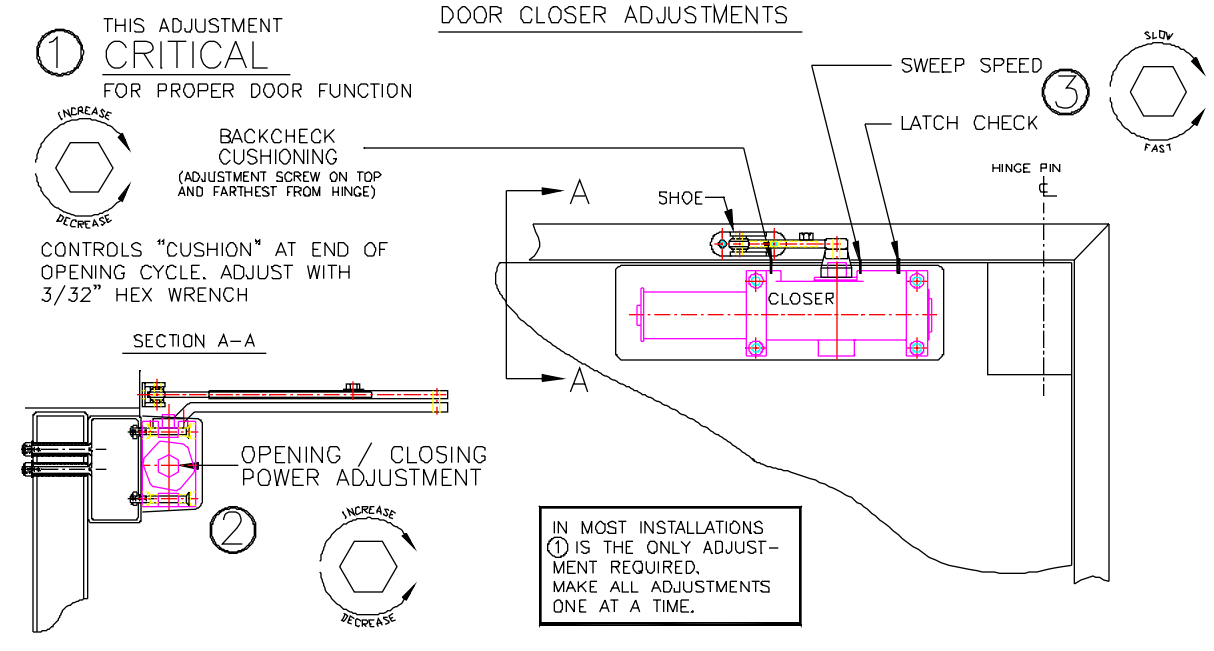

## REMOVE THE FRONT COVER

STEP 13: Adjust opening speed with the Air Pressure Regulator Valve. Pull knob "out" to adjust, then push knob "in" to lock in adjustment. Factory setting is 45 P.S.I.

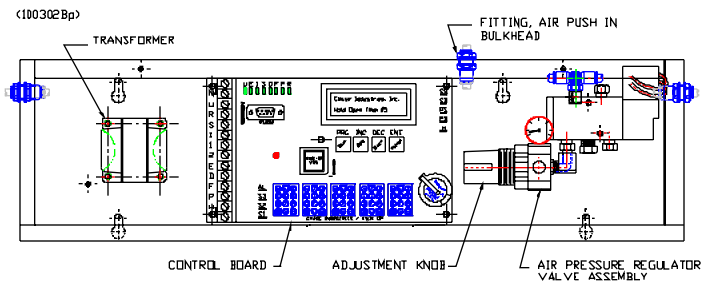

STEP 14: Adjust activating device according to manufacturer's instructions, specifications, or to owner's preference.

STEP 15: For future use, these installation instructions should be left with the proper authority on site.

**Flush or Infitting**

---

# Section 3C - Flush or Infitting

## OPENER / CLOSER INSTALLATION INSTRUCTIONS FLUSH OR INFITTING DOORS

STEP 1: Install the doors (if they are not already installed) according to manufacturer's instructions. DOORS MUST SWING FREELY OR OPERATOR WILL NOT FUNCTION PROPERLY.

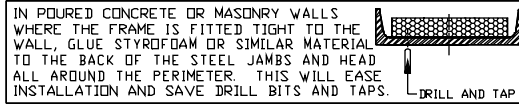

STEP 2: Install FLOOR MOUNTED DOOR STOPS.

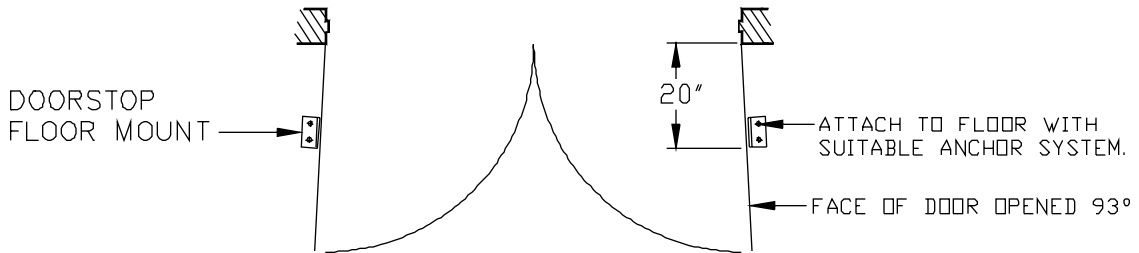

STEP 3: Mark (4) hole centers for T-BRACKET using template .  
NOTE: T-BRACKET must be a minimum of 1" from face of door in closed position.

Whenever possible, locate the T-BRACKET as close to the 1" minimum from face of door as is practical.

Reinforce jambs as required.

INSTALLATION TEMPLATE HEADER MOUNTED CYLINDER ASSY FOR STANDARD OPENING 90° to 95° **LEFT DOOR**

**DIRECTIONS FOR "STANDARD OPENING" OPENER LOCATION**

- 1- CLOSE DOOR COMPLETELY
- 2- FOLD TEMPLATE AT FOLD LINE
- 3- PLACE TEMPLATE AGAINST FACE OF DOOR AND AGAINST BOTTOM SIDE OF HEADER
- 4- WHILE HOLDING TEMPLATE TO DOOR AND HEADER PLACE, POSITION TEMPLATE SO THAT CENTER LINE OF HINGE IS ALIGNED WITH APPROPRIATE EDGE OF TEMPLATE
- 5- MARK HOLES FOR DRILLING WITH CENTER PUNCH

THIS EDGE FLUSH WITH CENTER LINE OF HINGE

STEEL: DRILL AND TAP 1/4"-20  
WOOD: DRILL 3/16" FOR #14 SCREWS

HOLLOW METAL JAMBS:  
DRILL 3/8" FOR NUT SERIES

FOLD TEMPLATE 90° AT LINE

AFTER FOLDING TEMPLATE PLACE THIS SURFACE ON FACE OF DOOR

4/8/99 ANY QUESTIONS? CALL 1-800-365-6736 1504300 (A)

INSTALLATION TEMPLATE HEADER MOUNTED CYLINDER ASSY FOR STANDARD OPENING 90° to 95° **RIGHT DOOR**

**DIRECTIONS FOR "STANDARD OPENING" OPENER LOCATION**

- 1- CLOSE DOOR COMPLETELY
- 2- FOLD TEMPLATE AT FOLD LINE
- 3- PLACE TEMPLATE AGAINST FACE OF DOOR AND AGAINST BOTTOM SIDE OF HEADER
- 4- WHILE HOLDING TEMPLATE TO DOOR AND HEADER PLACE, POSITION TEMPLATE SO THAT CENTER LINE OF HINGE IS ALIGNED WITH APPROPRIATE EDGE OF TEMPLATE
- 5- MARK HOLES FOR DRILLING WITH CENTER PUNCH

THIS EDGE FLUSH WITH CENTER LINE OF HINGE

STEEL: DRILL AND TAP 1/4"-20  
WOOD: DRILL 3/16" FOR #14 SCREWS

HOLLOW METAL JAMBS:  
DRILL 3/8" FOR NUT SERIES

FOLD TEMPLATE 90° AT LINE

AFTER FOLDING TEMPLATE PLACE THIS SURFACE ON FACE OF DOOR

4/8/99 ANY QUESTIONS? CALL 1-800-365-6736 1504300 (A)

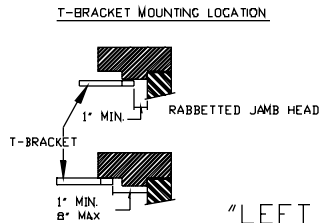
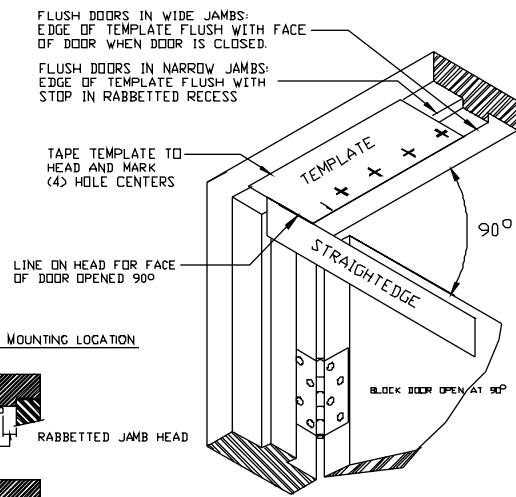

"LEFT HAND HINGE" SHOWN  
FLUSH OR IN-FITTING DOOR

## Section 3C - Flush or Infitting

### OPENER / CLOSER INSTALLATION INSTRUCTIONS FLUSH OR INFITTING DOORS

STEP 4: REFER TO THE 3 OPTIONS BELOW, DEPENDING ON THE JAMB STRUCTURE AND MOUNTING SYSTEM FURNISHED.

16 GAGE or HEAVIER JAMBS: Drill (4) 3/8" dia. holes thru head for 1/4"-20 NUT SERTS. See Jamb Detail No. 7

LESS THAN 16 GAGE: Drill and tap (4) 1/4"-20 thru head and reinforcement. See jamb details 8 or 10.

WELD BRACKET: Install Weld Bracket per Jamb Detail No. 9.

STEP 5: Install the T-BRACKET and ACTUATING ARM using the stainless steel screws provided.

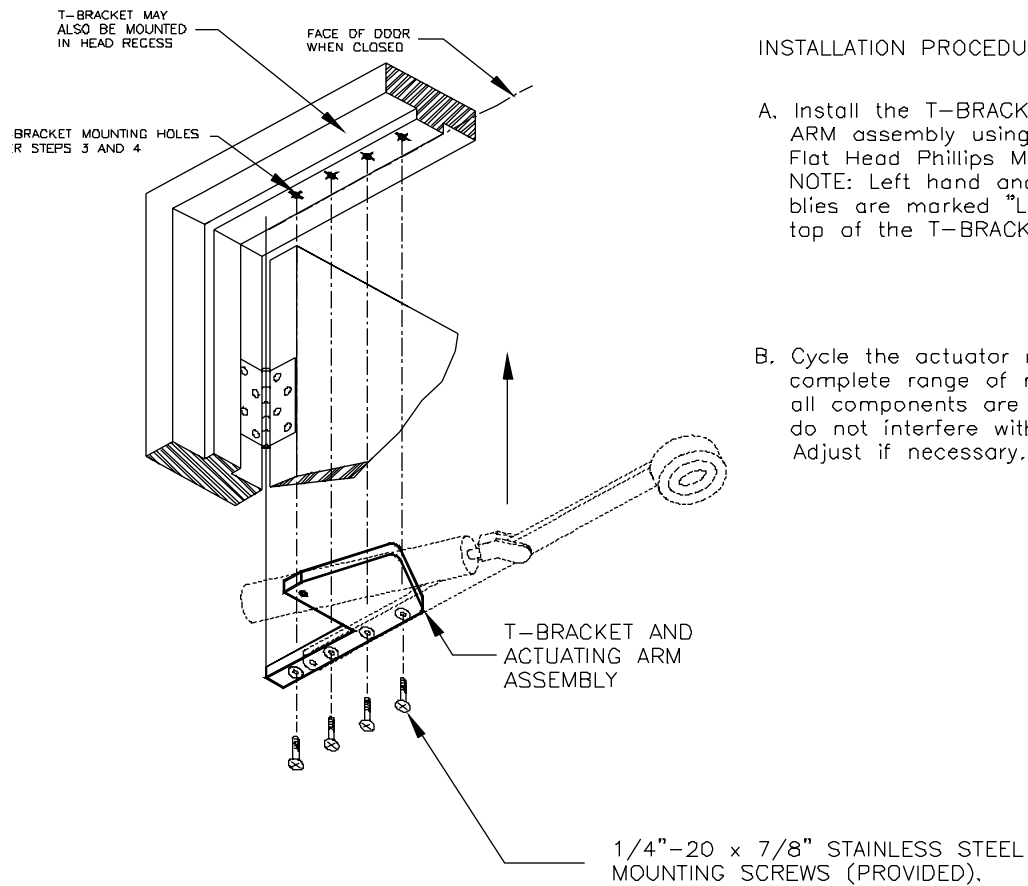

# Section 3C - Flush or Infitting

## OPENER / CLOSER INSTALLATION INSTRUCTIONS FLUSH OR INFITTING DOORS

STEP 6: Install CLOSER using template.

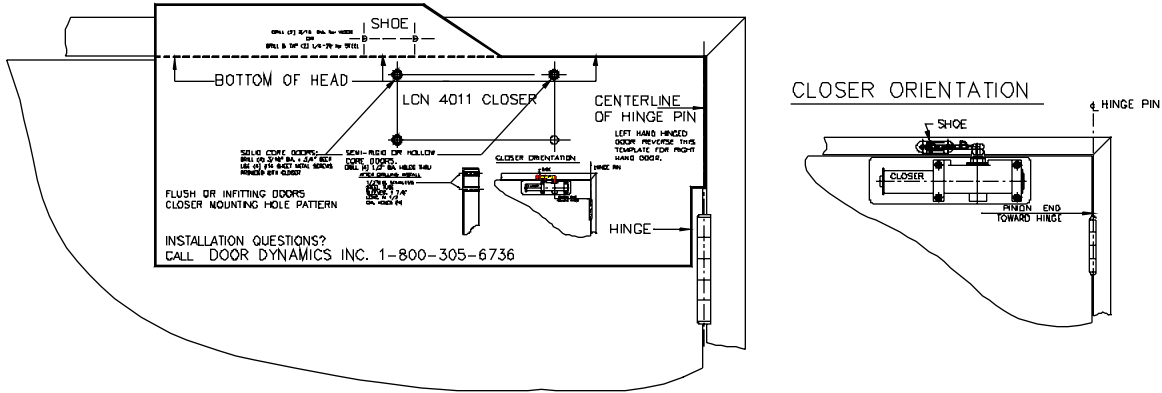

STEP 7: Install CONTROL ENCLOSURE to wall per template  
Mount with anchors and screws provided.

CONTROL ENCLOSURE TO BE MOUNTED AT SIDE OF OPENING AND NO MORE THAN 25' AWAY

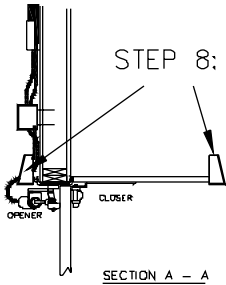
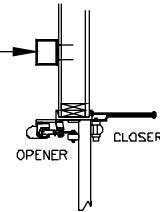

STEP 8: Install ACTIVATING DEVICE (motion detector, etc.) according to manufacturer's instructions using the (4) 8-32 x 1/4" Hex Washer Thread Forming Screws. Drill size #25.

STEP 9: Connect CONTROL ENCLOSURE to air supply and electrical supply, making sure ON/OFF switch is OFF (white showing).  
NOTE: Purge or blow out air lines prior to connecting air supply to control enclosure. WARRANTY MAY BE VOIDED IF THIS STEP IS OMITTED.

STEP 11: Connect ACTIVATING DEVICE(S) to CONTROL ENCLOSURE by inserting the plug into any of the 5 MOLEX receptacles located inside the control enclosure. Pass the open end of cable(s) through one or both of the strain relief connectors located on the bottom of the control enclosure and tighten. Connect cable to actuating device per the instructions attached to the cable.

NOTE: When longer runs of cables are required, splice the color coded wires to the pigtail leaving ALL connections inside the control enclosure.

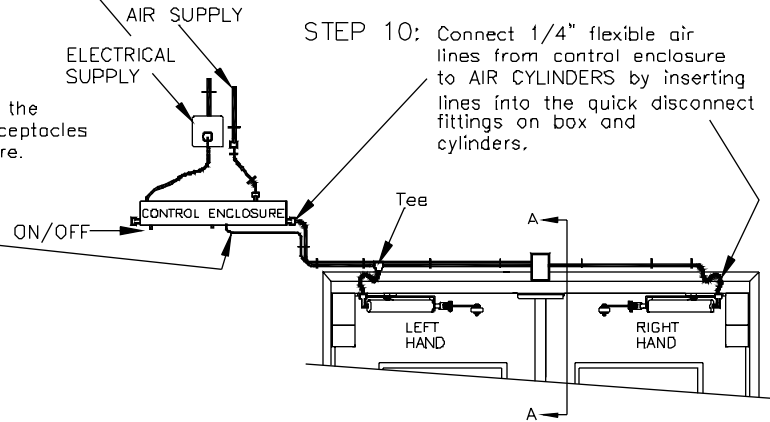

STEP 10: Connect 1/4" flexible air lines from control enclosure to AIR CYLINDERS by inserting lines into the quick disconnect fittings on box and cylinders.

# Section 3C - Flush or Infitting

## OPENER / CLOSER INSTALLATION INSTRUCTIONS FLUSH OR INFITTING DOORS

STEP 12: Turn on control enclosure and test unit. Adjust closer as necessary for smooth opening, backcheck cushioning, and latch check.

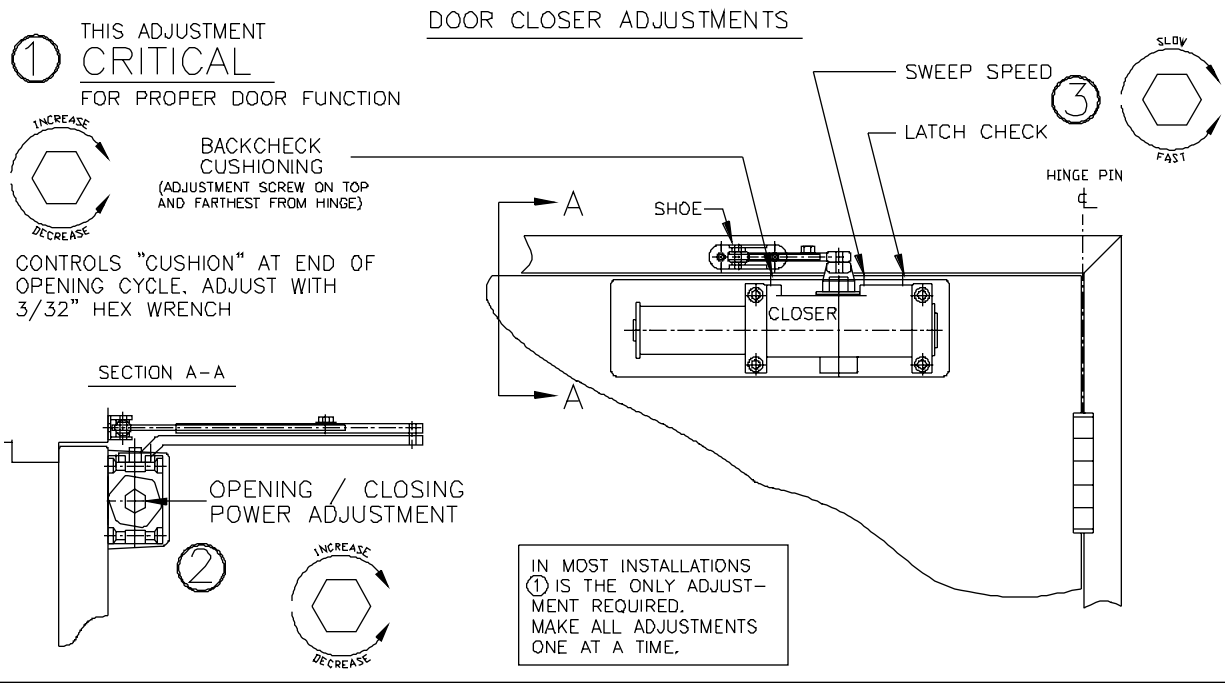

## REMOVE THE FRONT COVER

STEP 13: Adjust opening speed by turning air pressure regulator valve in control enclosure. Factory setting is 60 P.S.I.

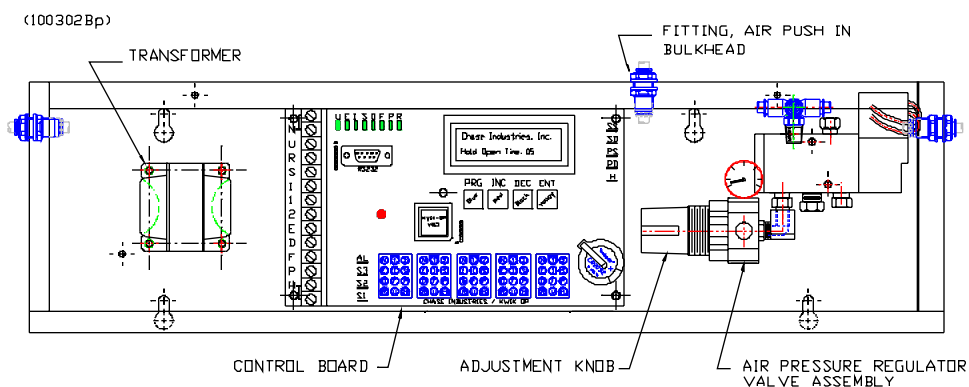

STEP 14: Adjust activating device according to manufacturer's instructions, specifications, or to owner's preference.

STEP 15: For future use, these installation instructions should be left with the proper authority on site.

---

## Section 4 - Operation

---

### Erich Industries

Performance Products Division Phone 800/305-6736

550 N. Nine Mound Road  
Verona, WI 53593

### OPERATING PROCEDURES FOR OPENERS

#### A) Start-up (refer to installation instructions for details)

1. Make sure air lines have been purged (blown free of particles in air line) prior to supply line hook-up to control enclosure. Attach supply line to control enclosure.
2. Plug in cord or hard wire to electric (110 volt) sources in accordance with local codes.
3. Depress ON-OFF switch to turn on.
4. Set activating devices to owner's requirements.
5. Adjust opening speed with air pressure control knob in control enclosure. Never lower more than 40 PSI or raise higher than 85 PSI.
6. Door should not slam open or closed. If this occurs, increase the back check on the door closer to a cushioned stop at the end of the cycle. Adjust the latch check on the closer for a cushioned close at the end of the closing cycle.

#### B) Operation

1. Depress ON-OFF switch to activate door operator and turn on.
2. Release ON-OFF switch to de-activate door operator and turn off.
3. All activating devices must be plugged into control enclosure to function.
4. Operators will not be damaged if held in closed or open position while activated for an extended period of time.

#### C) Emergency Operation

1. In case of a power outage or if turned off, the doors will open and close manually. The operator will not be damaged when operated manually.
2. Always turn operators off during a power outage and turn on when power is restored.

#### D) Shutdown

1. Use ON-OFF switch on the control enclosure to de-activate the operator. Turn off.
-

### Erich Industries

Performance Products Division Phone 800/305-6736

550 N. Nine Mound Road  
Verona, WI 53593

### MAINTENANCE PROCEDURES FOR “KWIK-OP”

#### A) Maintenance - Air Source (as applicable)

1. Service compressors, filters, etc. as per manufacturer’s instructions.
2. Service should be carried out in 3 month intervals, or as required. Consult this manual for details.

#### B) Maintenance - Operators

1. Manually open doors to check for “*free swing*”. Adjust and/or lubricate hinges.
  2. Check actuator arms for excessive play. If required, loosen set screw or lock nut and tighten bolt to remove play. Do not over tighten, which will cause binding. After tightening set screw or lock nut, check again to insure that the unit has free action.
  3. Check cylinder jamb nut and tighten (if required) with the cylinder vent on the bottom.
  4. Lubricate bearing points with spray lube.
  5. Check air filter on supply air line. Clean, drain, or replace as required.
  6. Check, air hoses and connections for leaks, kinks, or contact with moving parts. Correct as required.
  7. Check air pressure and opening speed. Adjust per instructions as required.
  8. Check closer back check, closing speed, and latch speed. Adjust per instructions as required.
  9. Check Time Delay period. Adjust per instructions as required.
  10. Service should be carried out in 3 month intervals along with compressor servicing, or as required.
-

### Erich Industries

Performance Products Division      Phone 800/305-6736

550 N. Nine Mound Road  
Verona, WI 53593

### TROUBLESHOOTING

#### 1. Unit Will Not Actuate

- a. Check for physical jamming or binding of door.  
(A minimum 1/16" gap must exist between the floor and the bottom seal of the door.)
- b. See if door will open using the HOLD OPEN switch on the control enclosure.  
If it **does work, go to (d) of these instructions.**  
The problem is with input devices or control circuit board.
- c. **Door does not open when using the HOLD OPEN switch mounted on the control enclosure:**  
problem is either with air supply or power supply.  
Open control enclosure and read gauge pressure.  
If open/close pressure is at least 30/20 PSI ➤ air supply is OK.  
If any lights are lit on the control circuit board ➤ the problem may be a faulty solenoid.  
If circuit board lights are all off ➤ the problem may be loss of electrical power.  
Make sure the electrical outlet feeding the control enclosure is working.  
If it is ➤ the problem may be a faulty transformer.
- d. **Door opens when using HOLD OPEN switch, but does not respond to other open signals.**  
Remove cover from control enclosure and observe the display on the control circuit board.  
It **should be lit.** If it is **not** ➤ replace the control unit board.
- e. Observe the status lights in the upper left corner of the control circuit board.  
The 2nd light from the left should light when any initiate signal is active (such as a sensing motion detector).  
If this light **does not indicate activity** ➤ most likely a faulty sensor device.

#### 2. Door Opens But Will Not Close

- a. Check for binding of actuator arm and cylinder.  
Check for **free movement** of the door.
  - b. Position of Safety Zone Sensor may cause it to "see" the door.
  - c. Program function may be incorrect.  
(Refer to programming instructions in section 8 of this manual.)
-

Continued...

### 3. Unit Actuates, Opens Door Correctly, Door Closes Slowly But Not Completely

- a. Check for *free movement* of door and action of door closer.  
Check sweep and latch adjustment of close.  
Increase door closer spring pressure if required (with corresponding adjustment of air pressure and opening speed as necessary).
- b. Check for *free movement* of actuator arm and cylinder.
- c. Check for release of exhaust pressure at solenoid by loosening the hose fitting at the solenoid.

### 4. Door Action Too Fast, Unable To Control

- a. Reduce air pressure to 40 PSI on air regulator and reset LCN hydraulic door closer backcheck using backcheck adjustment screw (see instructions included with hydraulic door closer). Then gradually increase air pressure (opening speed) to achieve full opening without “overswing” while making minor adjustments to the backcheck screw.

**Note:** The hydraulic door closer is used to cushion the stopping action of the door.

---

# Kwik-Op 600 Assembly and Parts List

## Exploded View

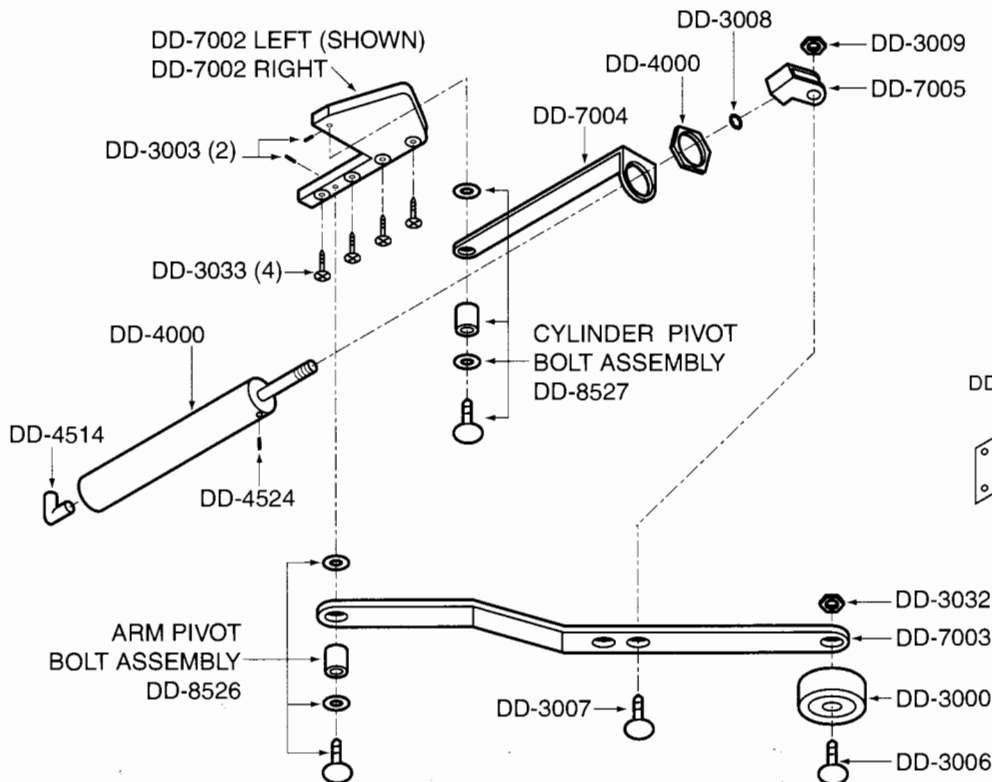

## Control Box

DD-8500

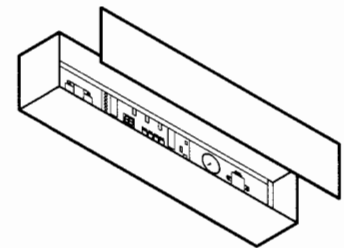

## Closer

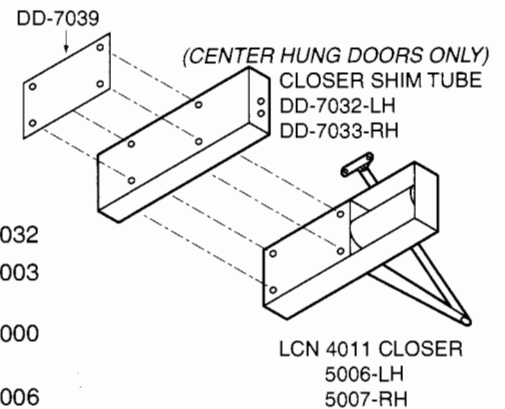

## Parts List

### Opener Parts

- DD 4000 Cylinder, 2" x 8" stainless steel
- DD 7002 T-bracket, right hand
- DD 7002 T-bracket, left hand
- DD 7003 Arm
- DD 7004 Cylinder bracket
- DD 7005 Clevis
- DD 3000 Wheel
- DD 8526 Arm bolt assembly with bearings
- DD 8527 Cylinder bolt assembly with bearings
- DD 3006 5/16-24 x 1-3/4" hex head cap screw
- DD 3007 5/16-24 x 1-1/2" hex head cap screw
- DD 3008 Jamnut 1/2" x 20
- DD 3003 1/4 - 20 set screw
- DD 3009 5/16 x 24 thin Nyloc nut
- DD 3033 1/4 x 20 x 7/8" flat head phillips

### DD 7039 Backer plate

- DD 4514 Swivel 90 degree elbow
- DD 4524 Vent plug
- DD 3032 5/16 Nyloc nut

### Closer Parts

- DD 5007RH LCN 4011 Closer, right hand
- DD 5006LH LCN 4011 Closer, left hand
- DD 7033 Closer shim tube, right hand
- DD 7032 Closer shim tube, left hand

### Opener Assemblies

- DD 8505 Left hand opener, complete assembly
- DD 8506 Right hand opener, complete assembly
- DD 8500 Control box

**Erich Industries, Inc.**  
**Performance Products Division**  
**AUTOMATIC DOOR OPENER**  
**ELECTRICAL WIRING DETAILS**

Our control box is microprocessor based to insure maximum reliability and flexibility for the user. The system has been designed to be easy to set up and operate. Directions for setting the proper program are in the Circuit Board User's Manual located elsewhere in this manual. The control unit is designed to be connected to a constant power source of 110VAC 60HZ or 230VAC 50HZ, which powers the control box and a wide variety of activation devices with 24VAC power.

Activating devices and input signals should be connected directly to the terminal strip located on the left side of the control board.

- N = Power Common Lead
- N = Power Common Lead
- U = Spare
- R = Remote Proof of Closure Signal
- S = Safety Signal
- I = Initiate Signal
- #1 = D 14-2 Control
- #2 = D 14-2 Control
- E = Spare
- D = DB11 Signal (Photocell)
- F = Fire Signal
- P = Proof of Closure Switch Signal
- H = 24V Power
- H = 24V Power

Below we provide wiring details for a variety of activation and safety devices available from Erich Industries. In most cases other manufacturers models can also be wired to the system in a similar fashion. Please consult with the manufacturer of that particular unit with questions or call us.

**E-2010 (MS D38) Motion Detector and  
E-2020 (BEA Eagle) Motion Detector**

- #1 to H
- #2 to N
- #3 to I
- #4 to N

**E-3010 (MS DH97) Presence Sensor**

- Red to H
- Black to N
- Yellow to S
- White to N

**E-3060 (MS GD11S) Photoeye Safety Beam**

- Transmitter: White to H  
Black to N
- Receiver: White to H  
Black to N  
Gray to D  
Green to N

**E-5010 (MS 216) Touchless Switch**

- Red to H
- Green to N
- Red to N
- Blue to I

**E-3070 (BEA Microcell) Photoeye Safety Beam**

- #1 to H
- #2 to N
- #3 to D
- #4 to N

**E-5020 (BEA MS-08) Touchless Switch**

- Red to H
- Black to N
- White to N
- Green to I

**E-4020 (MS 99) Push Plate**

- Normally Open to I
- Common to N

**E-6010 (VEE CP1) Pull Cord**

- Normally Open to I
- Common to N

**E-3060 (MS SSS-1) Door Mounted Safety Sensor (when utilized on “push” side of door)**

Red to H  
Black to N  
Yellow to I  
White to N  
Green to No Connection

Additional questions can typically be answered by calling the factory technical support staff at 1-800-882-5839.

Revision 4/15/07

# Chase Industries Kwik Op Circuit Board User's Manual

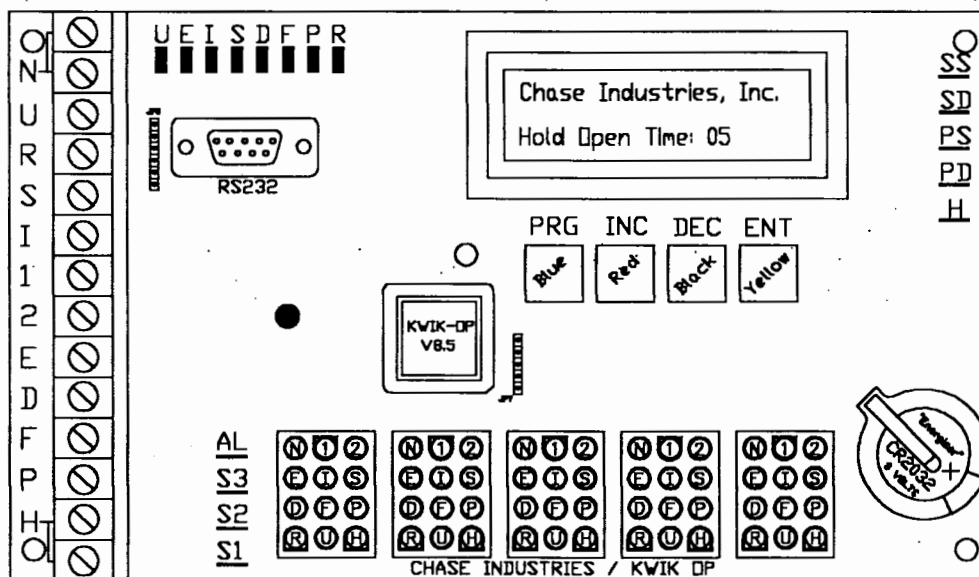

# Chase Industries Kwik-Op Door Control

## Control Board Software User's Manual

### General

#### Status/Health LED

A single red LED displays the general health of the controller. These indications are summarized in the following table:

Indication	Meaning
1 short blink every second	Controller is running normally
1-7 blinks every 6.4 seconds	Error condition
LED off	Controller failure
LED on for 5 seconds then off	Internal failure; clock failure or firmware corruption

In the case of errors, the number of times the LED blinks within each 6.4 second indicates which error(s) have been detected. The number of blinks is the sum of the failure counts in the table below:

Error	Blink Code
LCD Controller Failure	1
Non-volatile storage read/write failure	2
Non-volatile storage checksum error	4

The number of blinks in error mode indicates the *sum* of these blink codes, e.g. a combined non-volatile storage R/W failure with data corruption will result in a blink count of 6 each 6.4 seconds.

#### LCD Controller Failure

This error is indicated when proper communications cannot be established with the liquid crystal display module's controller. The error is cleared at power-up. If this indication persists, it indicates that the LCD module probably needs to be replaced.

#### Non-volatile Storage Read/Write Failure

This error indicates that the non-volatile storage contained in the real-time clock is unreliable. The error is cleared at power-up and is tested during each initialization.

#### Non-volatile Storage Checksum Failure

This error is an indication that the non-volatile parameter storage was corrupt when it was loaded at power-up. This is a normal indication when the control is first powered up prior to being programmed. This condition is cleared when any operation is performed that writes the non-volatile parameters, such as pressing the **PRG** button while in Local Programming Mode.

# Programming

Setting the functional parameters in the control can be accomplished by either using the operator keyswitches on the control marked **PRG**, **INC**, **DEC** and **ENT** or by connecting a serial terminal to the control. Using the keyswitches is referred to as "Local Programming" while using a serial device is referred to as "Remote Programming". Only one programming method can be in use at a given time.

## Parameters

### Local Programming

When the controller is not any programming mode, pressing the **PRG** key on the board will place the control into Local Programming Mode and Remote Programming Mode is inhibited.

While in Local Programming Mode, the keys on the control perform the following functions:

<b>PRG</b>	Advances to the next value to be displayed or changed. This key auto-repeats.
<b>INC</b>	Increments the current value of the displayed parameter. Values "wrap around" from maximum value to minimum values. This key auto-repeats.
<b>DEC</b>	Decrements the current value of the displayed parameter. Values "wrap around" from minimum value to maximum values. This key auto-repeats.
<b>ENT</b>	Pressing this key causes any changes made to be stored in non-volatile storage so that they will be loaded when the control is next powered up. Note that if this key is <i>not</i> pressed, any changes in values will not be stored and will be temporary. <sup>1</sup>

### Remote Programming

Remote programming of the unit is accomplished by connecting a standard DA-9P to DB-25 (or DB-9) "straight through" serial cable to the DA-9S onboard connector.<sup>2</sup> Only the transmit and receive data lines are required for operation in addition to a ground. The connected serial device must be set to 9600 baud, 8-bit data and no parity. For best results, the serial device should emulate an ANSI terminal and should have "destructive backspace" enabled and "local echo" off.

---

<sup>1</sup> It is not possible to make "temporary" changes to the time or date. Pressing **ENT** programs the clock, exiting programming mode without saving data doesn't.

<sup>2</sup> The actual serial connector and RS-232C electrical interface are optional. Remote serial programming can still be accomplished by providing a stand-alone TTL to RS-232C interface and converting the serial signals presented to the serial option connector instead.

## Standard Menu

Remote Programming mode is initiated by sending a single Carriage Return character. The controller will respond with the remote menu<sup>3</sup>:

CHASE INDUSTRIES KWIK-OP

- A) HOLD OPEN TIME
- B) VALID SAFETY
- C) TIME TO CLOSE
- D) DELAY TO SECOND
- E) MAGNETIC STRIKE
- F) OPERATION MODE
- G) COUNT TO PURGE
- H) PURGE LENGTH
- I) SET DATE
- J) SET TIME
- K) ZONE START
- L) ZONE END
- M) ZONE ACTIVE DAYS
- N) LANGUAGE

Enter Your Choice : \_

To select an item, enter the letter indicated (do not press **ENTER** ) and you will be prompted with the current value and, if applicable, the range of acceptable values, such as:

Enter Your Choice: **D**  
DELAY TO SECOND= 05 SECONDS, RANGE: 00-99, NEW VALUE=\_

If no value is entered, or if the entry is invalid, the existing value will not be changed. If no keys are pressed for 30 seconds, the controller will automatically exit the Remote Programming Mode. While in Remote Programming Mode, the on-board programming switches are disabled and the controller's LCD will show the message "REMOTE PROGRAM MODE ACTIVE".

In addition to the visible menu choices (A-N), additional special codes may be entered at this menu:

- \ Toggle debug mode
- ? Display Status
- S Special Factory Menu

## Debug Mode

While in Debug Mode, the controller's LCD will show the state of the various AC control output lines:

```
ALS3S2S1SSSDPSPD  
- - * * - - - -
```

A "-" symbol indicates that the related output is off, a "\*" indicates it is on.

## Status Display

The status display shows some internal settings and then reprompts the main menu.

---

<sup>3</sup> The menu text shown is for the default language (English).

## **Special Factory Menu**

The Special Factory Menu is:

FACTORY SPECIAL MENU

- A) CLEAR COUNTER
- B) SET COUNTER

Enter Your Choice : \_

These command clear and set the activation cycle counter.

## ***Special Modes***

### **Factory Defaults**

To return all parameters to factory default values, press and hold the **INC** and **DEC** switches when the control is powered up. The LCD will display a message requiring confirmation to restore defaults; pressing **ENT** confirms.

### **“Flip-Flop” Mode**

The “Flip-Flop” mode is intended for functional checkout of the control. It is activated by pressing the **PRG** switch when the control is powered up. Press the **ENT** switch to confirm activating Flip-Flop mode. Once activated, this mode continues until the control is powered down.

Below is a list of the parameters presently being used to control operation of the control board, and a description of what each parameter does.

<u>Parameter</u>	<u>Setting</u>	<u>Range</u>	<u>Function</u>	Board Connections
P1 (A)	05	02-99	Sets the hold open time. If the value of P6 is 10, 11, 12 or 13 the value of P1 is ignored. If the value of P6 is 14, 15, 16, or 17 then the unit is changed to toggle mode with a timeout enabled also.	
P2 (B)	1.0	0.0-9.9	Tells the computer how many tenths of seconds a safety signal has to last to be considered valid.	S
P3 (C)	4.0	0.0-9.9	Tells the computer how many tenths of seconds during door closing time to wait for the safety device to detect the door. At the end of this time or after getting a safety signal, the system considers the door shut.	S
P4 (D)	05	00-99	Determines delay till sending a signal to open a second set of doors. Also delays a signal to a secondary door strike.	S2
P5 (E)	01	01-04	Sets the magnetic strike time. Even if no strike is used, this value is not allowed to go below 1.	S1
P6 (F)			Operation Mode Settings. See page 38 for additional details.	
P7 (G)	05	00-99	Sets the number of door cycles to count between the activation of the air-tank purge signal.	PD
P8 (H)	0.2	0.0-9.9	Sets the amount of time that the air-tank purge signal is to stay on.	PD

See the following page for determination of proper value for Parameter "P6"

## Operation Mode Abbreviations

LCD Screen Display	Description
<b>STD TOG TIME-OUT</b>	Standard Toggle Mode Time-Out – door open when requested and doors close when requested. However, if the request to close is not received within the set amount of time (“Time To Close”) – the doors will close automatically.
<b>STD TOGGLE MODE</b>	Standard Toggle Mode – doors open when requested and doors close when requested – no timer function.
<b>STD TIMER MODE</b>	Standard Timer Mode – <b>Normal setting</b> , doors open when requested and close automatically after the “Time To Close” input time has been reached.
<b>TERMINA TIME-OUT</b>	Terminate Time-Out (Cancels Time Out Mode)
<b>INT TIMER MODE</b>	Interlock Timer Mode - Standard Interlock Timer Mode, doors open when requested and close automatically after the “Time To Close” input time has been reached.
<b>INT TOGGLE MODE</b>	Interlock Toggle Mode, first set of doors opens when requested, and doors close when requested - then, the second set of doors open. When requested the second set of doors close – no timer function.

Operation Mode is obtained by pressing the Program “PRG” (Blue Button) six times until “Operation Mode” is seen on the LCD Screen.

Using the Increase “INC” (Red Button) or Decrease “DEC” (Black Button) press until the Mode required is observed on the Screen.

After selecting the Mode press Enter “ENT” (Yellow Button) to store the Mode into memory.

**Note:** this setting is maintained even if the power is loss. If Enter is not pressed, the Mode selected will be temporary and will not be stored into memory.

**Interlock** – definition – first sets of doors must be closed before the second set of doors can open.

# Section 9 - Options

## OPENER / CLOSER INSTALLATION INSTRUCTIONS FLUSH OR INFITTING DOORS – HINGE SIDE COMPONENT MOUNTING SYSTEM

STEP 1: Install the doors (if they are not already installed) according to manufacturer's instructions. DOORS MUST SWING FREELY (GASKETS MUST NOT DRAG ON FLOOR OR HEADER) OR OPERATOR WILL NOT FUNCTION PROPERLY.

STEP 2: Install FLOOR MOUNTED DOOR STOPS.

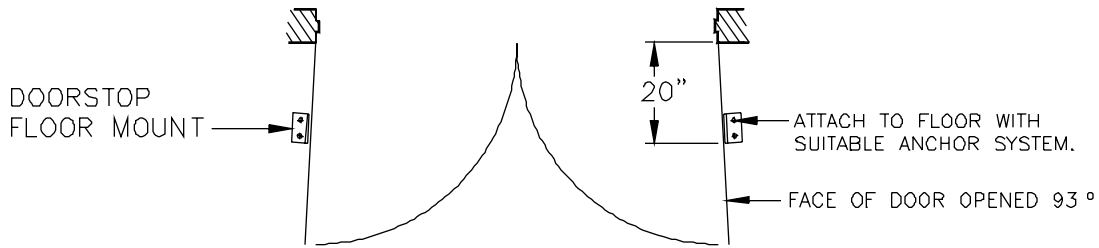

STEP 3: Orient Hinge Side Component Mounting Bracket – Left Hand, and Right Hand on their respective door panels (opener mounting tab is always toward the hinge), at 1 1/2" from the hinge to the end of the bracket, and with the notch flush with the top of the door panel.

Drill (2) holes as noted for wood or steel doors.  
Insert (2) bracket mounting screws as noted.

### ③ MOUNTING BRACKET HOLE PATTERN

LOCATE MOUNTING BRACKET  
1 1/2" FROM THE HINGE  
AND WITH THE NOTCH EVEN  
WITH THE TOP OF THE DOOR.

MARK AND DRILL (2) MOUNTING  
SCREW HOLES, AND MOUNT WITH:  
2-#14x1 1/4" SCREWS(WOOD DOOR)  
OR  
2-1/4"-20x1 1/2" SCREWS(STEEL DOOR)

"LEFT HAND HINGE" SHOWN  
RIGHT HAND IS MIRROR IMAGE

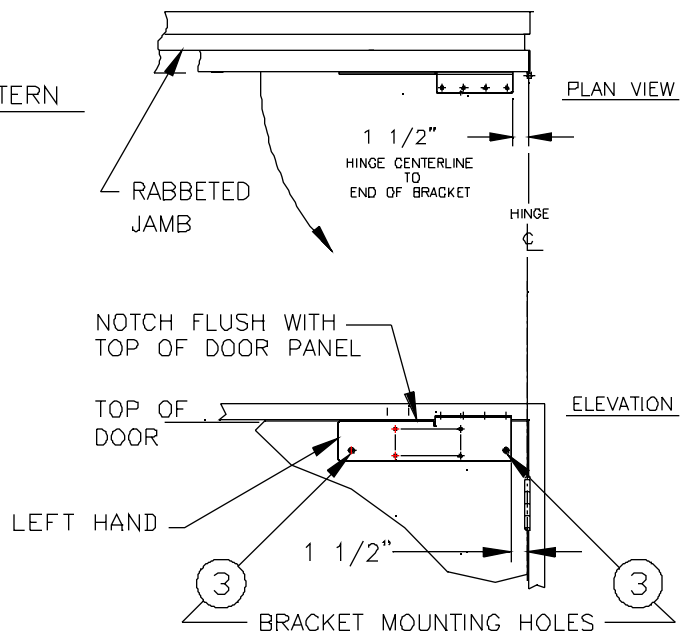

## OPENER / CLOSER INSTALLATION INSTRUCTIONS FLUSH OR INFITTING DOORS – HINGE SIDE COMPONENT MOUNTING SYSTEM

STEP 4: Using the mounted Hinge Side Component Mounting Bracket L or R as a template, drill (and tap) (4) holes as noted for wood or steel doors.

### 4 CLOSER MOUNTING PATTERN

USING THE MOUNTED BRACKET AS A TEMPLATE:  
 STEEL DOOR: DRILL #7 & TAP (4) 1/4-20  
 WOOD DOOR: DRILL (4) 3/16 $\phi$  FOR #14 SCREWS  
 SEMI-HOLLOW OR  
 COMPOSITE DOOR: DRILL 1/2 $\phi$  THROUGH AND  
 INSERT SSTL SLEEVES

NOTE:  
 Watch drilled hole depth on Steel or Wood doors:  
 DO NOT DRILL THROUGH DOOR unless required

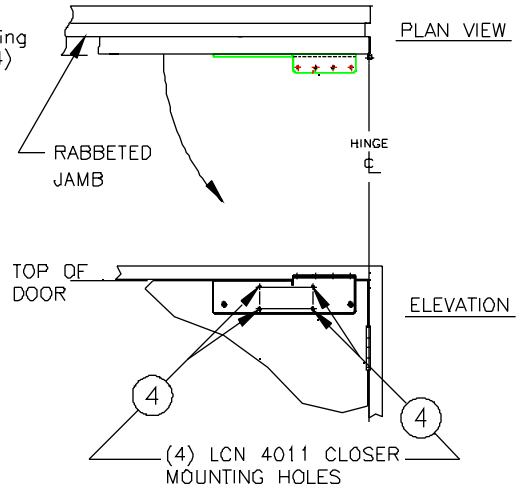

STEP 5: Install the T-BRACKET and ACTUATING ARM using the stainless steel screws provided.

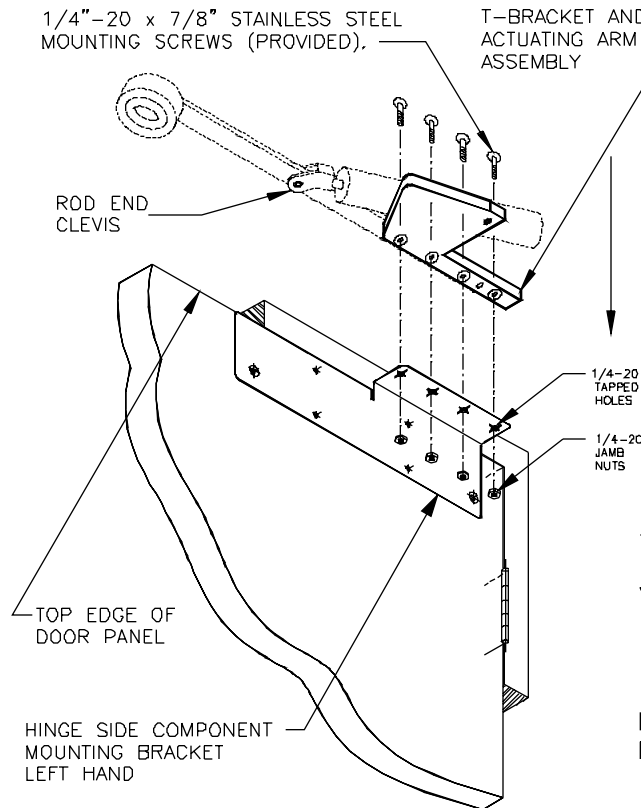

### INSTALLATION PROCEDURE

A. Install the T-BRACKET and ACTUATING ARM on the MOUNTING BRACKET using the (4) 1/4-20x7/8" Flat Head Phillips Machine Screws.

NOTE: Left hand and Right hand assemblies are marked "L" or "R" on the top of the T-BRACKET.

B. Cycle the actuator manually through it's complete range of motion to insure that all components are attached properly and do not interfere with any other components. Adjust if necessary.

C. Install the (4) 1/4-20 Jamb Nuts on the Mounting Screws.

To achieve MAXIMUM DOOR OPENING – with the cylinder fully retracted, loosen the Jamb Nut and rotate the Cylinder Rod in the Clevis out (counterclockwise) until the Roller is 1/16" from the head. Maintain six (6) turns of engagement of the Rod End in the Clevis.

LEFT HAND INSTALLATION SHOWN  
 RIGHT HAND IS MIRROR IMAGE.

## OPENER / CLOSER INSTALLATION INSTRUCTIONS FLUSH OR INFITTING DOORS – HINGE SIDE COMPONENT MOUNTING SYSTEM

STEP 6: Install CLOSER using the MODIFIED manufacturer's template to locate and drill SHOE mounting holes. Use fasteners provided by manufacturer to mount CLOSER and SHOE.

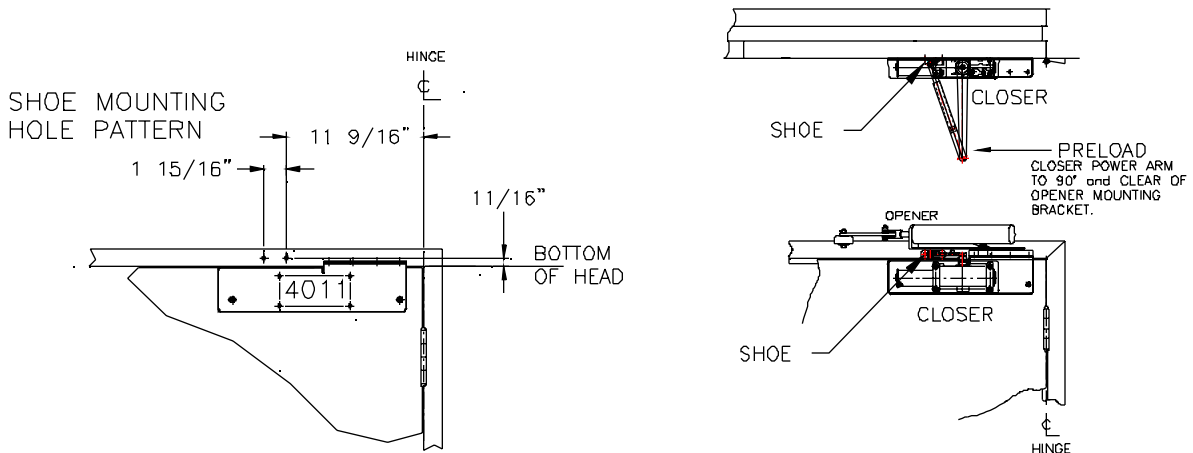

STEP 7: Install CONTROL ENCLOSURE to wall per template. Mount with anchors and screws provided.

CONTROL ENCLOSURE to be MOUNTED AT SIDE OF OPENING AND NO MORE THAN 25' AWAY.

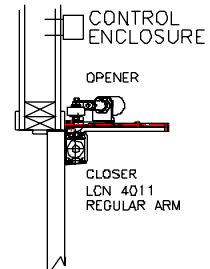
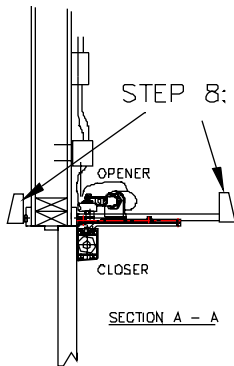

STEP 9: Connect CONTROL ENCLOSURE to air supply and electrical supply, making sure ON/OFF switch is OFF (white showing). NOTE: Purge or blow out air lines prior to connecting air supply to control enclosure. WARRANTY MAY BE VOIDED IF THIS STEP IS OMITTED.

STEP 11: Connect ACTIVATING DEVICE(S) to CONTROL ENCLOSURE by inserting the plug into any of the 5 MOLEX receptacles located inside the control enclosure. Pass the open end of cable(s) through one or both of the strain relief connectors located on the bottom of the control enclosure and tighten. Connect cable to actuating device per the instructions attached to the cable.

NOTE: When longer runs of cables are required, splice the color coded wires to the pigtail leaving ALL connections inside the control enclosure.

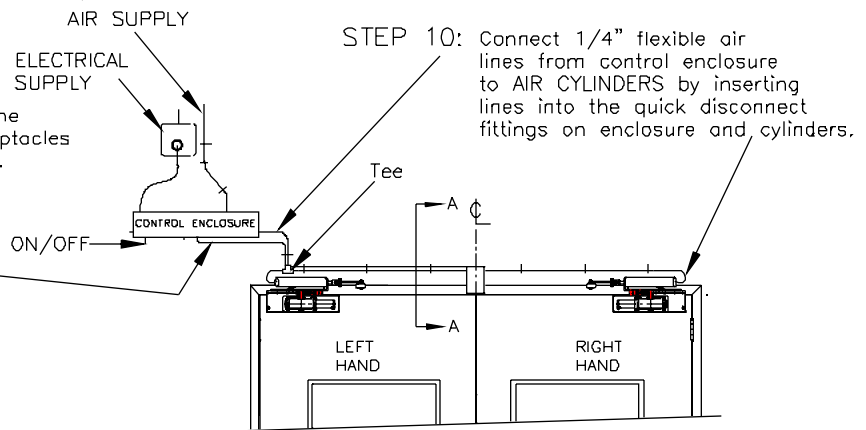

# Section 9 - Options

## OPENER / CLOSER INSTALLATION INSTRUCTIONS PUSH SIDE COMPONENT MOUNTING SYSTEM

STEP 1: Install the doors (if they are not already installed) according to manufacturer's instructions. DOORS MUST SWING FREELY (GASKETS MUST NOT DRAG ON FLOOR OR HEADER) OR OPERATOR WILL NOT FUNCTION PROPERLY.

STEP 2: Install FLOOR MOUNTED DOOR STOPS.

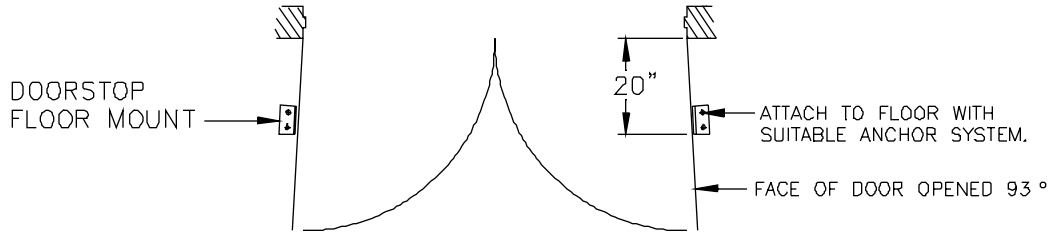

STEP 3: HOLE PATTERN LAYOUT

Open door panel(s) 90° and block in place. Project a line from the face of the door across the lower surface of the head.

Orient Push Side Component Mounting Bracket – Right Hand, and Left Hand on their respective sides of the frame head at 2" from the end of Bracket TO THE 90° line on head. RABBETED JAMBS ONLY; make sure that the lower surface of the long leg lies below the jamb stop (to allow for opener arm clearance).

Shim rabbeted jambs with Push Side Shim (5/16 x 1 1/2 x 9").

- (NUM) Plumb Closer Mount Face of Bracket and drill appropriate dia. hole for fastener. Install Bracket Plumb Fastener and tighten until Closer Mounting Face is plumb.
- (NUM) Mark the (4) vertical holes thru the Bracket by spot drilling centers with a 5/16Ø drill bit.
- (NUM) Mark the (4) Closer Mounting CLEARANCE holes by spot drilling thru the tapped holes with a 3/16Ø drill bit. SPOT DRILL (8) ONLY – DO NOT DRILL THRU.

Drill (and tap if req'd) (4) vertical holes to mount Bracket. Drill 5/16Ø CLEARANCE holes for Closer Mounting Fasteners as req'd.

- (NUM) Remount Push Side Component Mounting Bracket with the (1) vertical fastener and the (1) horizontal bracket plumbing fastener. Check plumb of Closer Mounting Face.

MOUNT PUSH SIDE BRACKET USING:  
2- #14 SCREWS INTO WOOD  
OR  
2- 1/4-20 SCREWS INTO STEEL

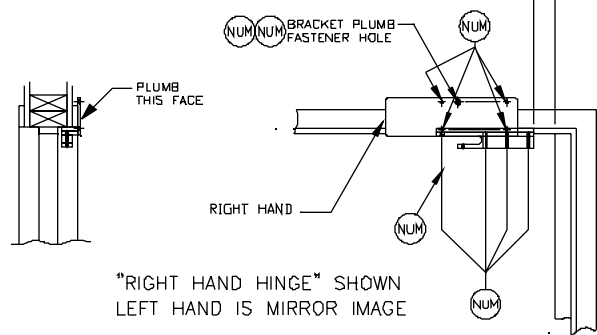
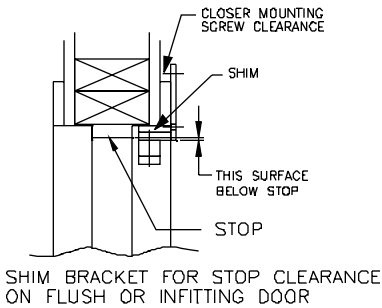
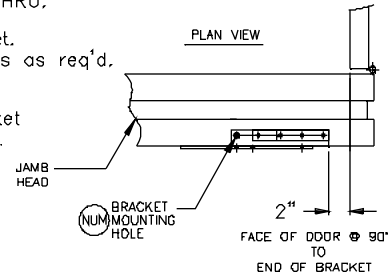

# Section 9 - Options

## OPENER / CLOSER INSTALLATION INSTRUCTIONS PUSH SIDE COMPONENT MOUNTING SYSTEM

### STEP 4: CLOSER MOUNTING

Mount the CLOSER POWER ARM on the CLOSER BODY per manufacturer's instructions. (Step #4 on LCN 4011 instruction sheet.)

Mount Closer on Push Side Mounting Bracket using the (4) 1/4-20x2 1/4" Flat Head Machine Screws in manufacturer's hardware.

Cycle the Power Arm for 180° to insure that it clears the frame head (centerhung door) or frame head stop (infitting door).

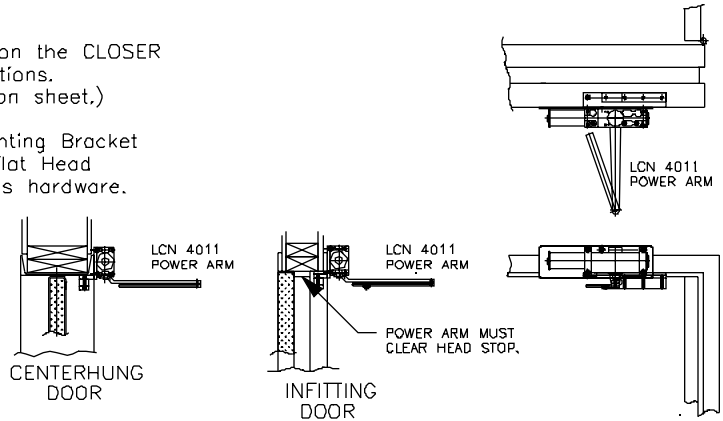

### STEP 5: Install the T-BRACKET and ACTUATING ARM using the stainless steel screws provided.

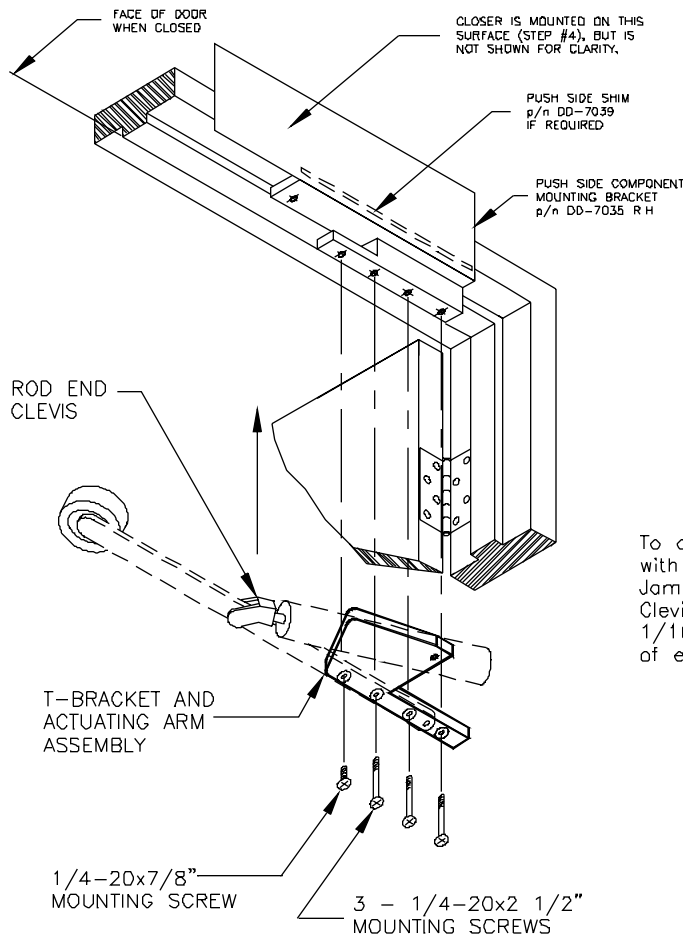

### INSTALLATION PROCEDURE

A. Install the T-BRACKET and ACTUATING ARM on the MOUNTING BRACKET using the (1) 1/4-20x7/8" and (3) 1/4-20 or #14 x 2 1/2" screws provided.

NOTE: Left hand and Right hand assemblies are marked "L" or "R" on the top of the T-BRACKET.

B. Cycle the actuator manually through its complete range of motion to insure that all components are attached properly and do not interfere with any other components. Adjust if necessary.

To achieve MAXIMUM DOOR OPENING - with the cylinder fully retracted, loosen the Jamb Nut and rotate the Cylinder Rod in the Clevis out (counterclockwise) until the Roller is 1/16" from the door. Maintain six (6) turns of engagement of the Rod End in the Clevis.

RIGHT HAND INSTALLATION SHOWN  
LEFT HAND IS MIRROR IMAGE.

# Section 9 - Options

## OPENER / CLOSER INSTALLATION INSTRUCTIONS PUSH SIDE COMPONENT MOUNTING SYSTEM

### STEP 6: MOUNT SHOE

Install SHOE/ADJUSTABLE ARM using MODIFIED manufacturer's template to locate and drill shoe mounting holes. Use fasteners provided by manufacturer to mount SHOE.

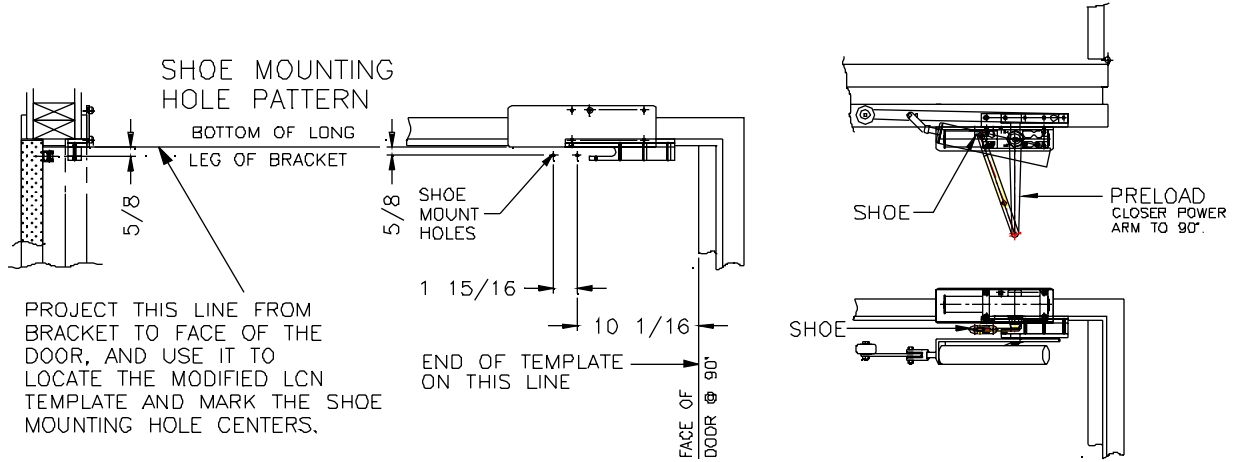

STEP 7: Install CONTROL ENCLOSURE to wall per template. Mount with anchors and screws provided.

CONTROL ENCLOSURE TO BE MOUNTED AT SIDE OF OPENING AND NO MORE THAN 25' AWAY.

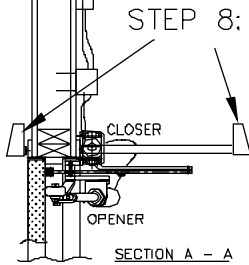
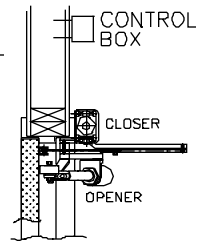

STEP 8: Install ACTIVATING DEVICES (motion detectors, etc.) according to manufacturer's instructions using the (4) 8-32 x 1/4" Hex Washer Thread Forming Screws. Drill size #25.

STEP 9: Connect CONTROL ENCLOSURE to air supply and electrical supply, making sure ON/OFF switch is OFF (white showing). NOTE: Purge or blow out air lines prior to connecting air supply to control enclosure. WARRANTY MAY BE VOIDED IF THIS STEP IS OMITTED.

STEP 11: Connect ACTIVATING DEVICE(S) to CONTROL ENCLOSURE by inserting the plug into any of the 5 MOLEX receptacles located inside the control enclosure. Pass the open end of cable(s) through one or both of the strain relief connectors located on the bottom of the control enclosure and tighten. Connect cable to actuating device per the instructions attached to the cable.

NOTE: When longer runs of cables are required, splice the color coded wires to the pigtail leaving ALL connections inside the control enclosure.

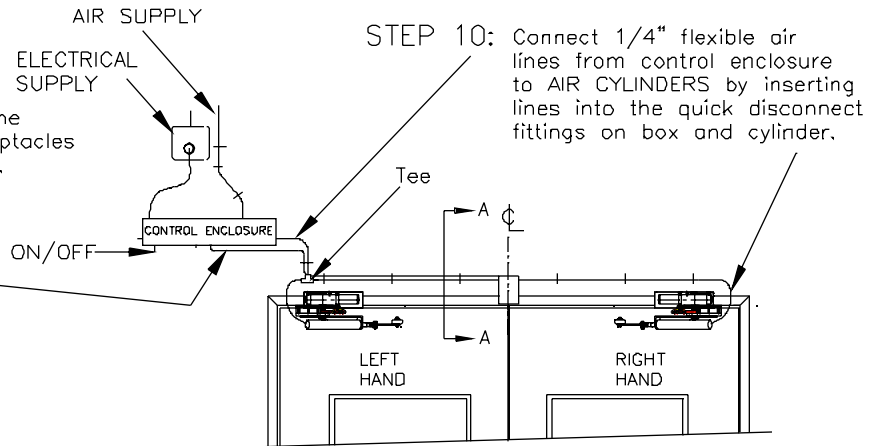

**Instruction Sheets / Drawings**

---

## NO-RISE CONVERSION KIT INSTALLATION INSTRUCTIONS

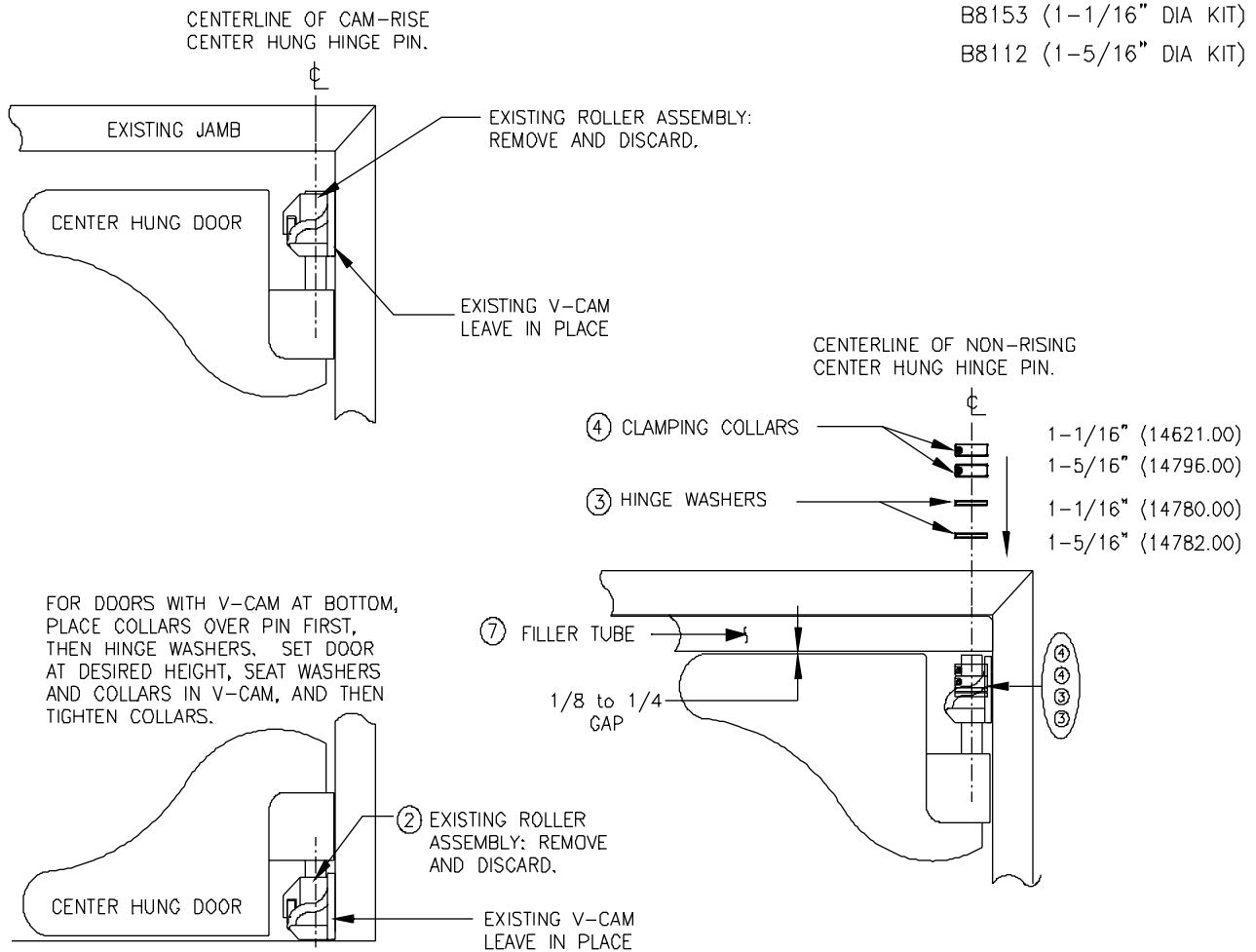

### NO-RISE CONVERSION INSTALLATION PROCEDURE

- ① PLACE BLOCK UNDER DOOR PANEL TO HOLD IT AT EXISTING HEIGHT.
- ② REMOVE AND DISCARD EXISTING ROLLER ASSEMBLY AND SPRINGS.
- ③ PLACE (2) WASHERS OVER HINGE PIN AND SEAT IN BOTTOM OF V-CAM RECESS.
- ④ SPRAY WITH SILICONE OR OTHER PLASTIC LUBRICANT ON BOTTOM, IN BETWEEN, AND ON TOP OF WASHERS.
- ⑤ PLACE (2) CLAMPING COLLARS OVER PIN AND SEAT FIRMLY ON WASHERS. TIGHTEN SETSCREWS FIRMLY.
- ⑥ OPEN DOOR TO ENSURE BOTTOM SWEEP DOES NOT DRAG ON FLOOR, ADJUST AS NECESSARY BY REPOSITIONING CLAMP COLLARS.
- ⑦ INSTALL FILLER TUBE: SEE INSTRUCTION SHEETS/DRAWINGS SECTION. NOTE 1/8" TO 1/4" GAP BETWEEN TOP OF DOOR AND TUBE/HEAD.

FILLER TUBE SIZING FOR CAM-LIFT TO NO-RISE HINGE CONVERSION

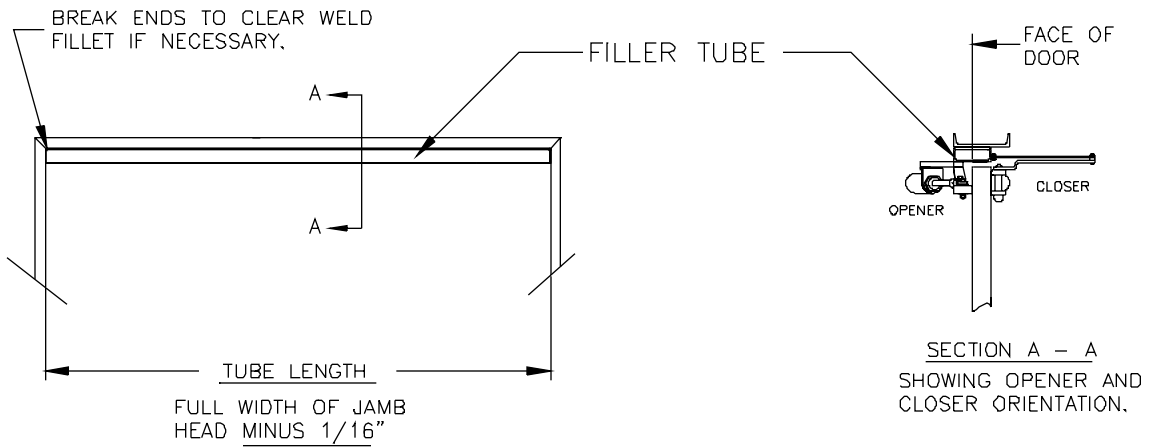

FILLER TUBE TO BE: \_\_\_\_\_" WIDE x \_\_\_\_\_" HIGH x \_\_\_\_\_" LONG x 1/4" WALL  
 RECTANGULAR STEEL TUBE  
 \_\_\_\_\_ REQUIRED - BY OTHERS.

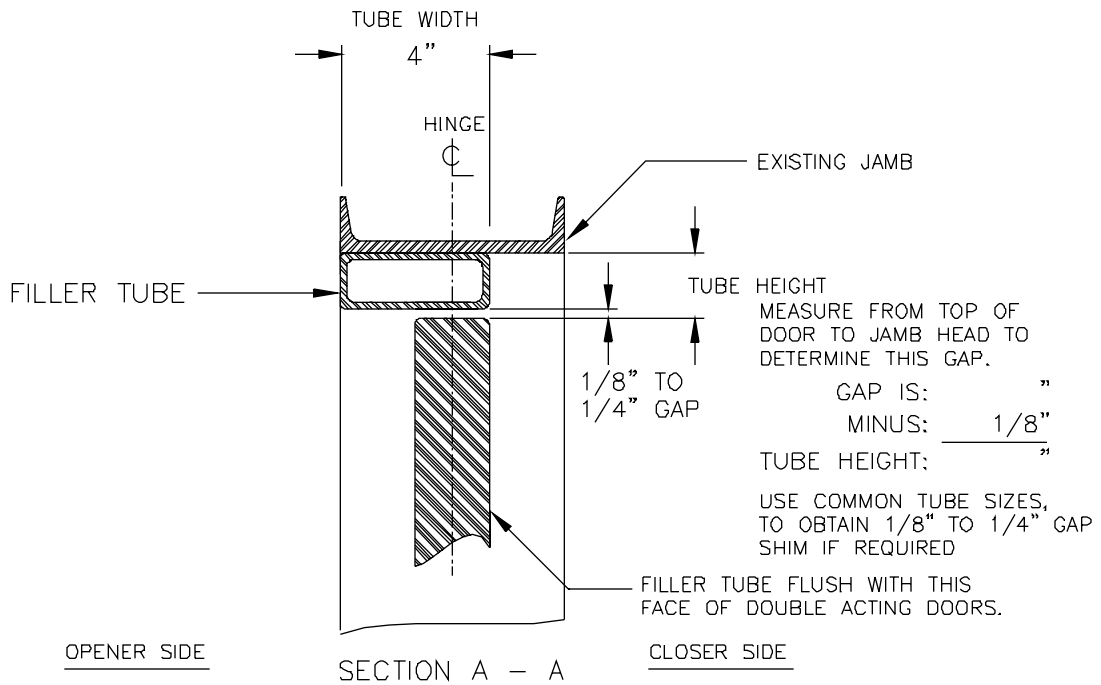

Double Acting (Center Hung) Doors: Jamb & Head Construction Detail

JAMB DETAIL NO. 1

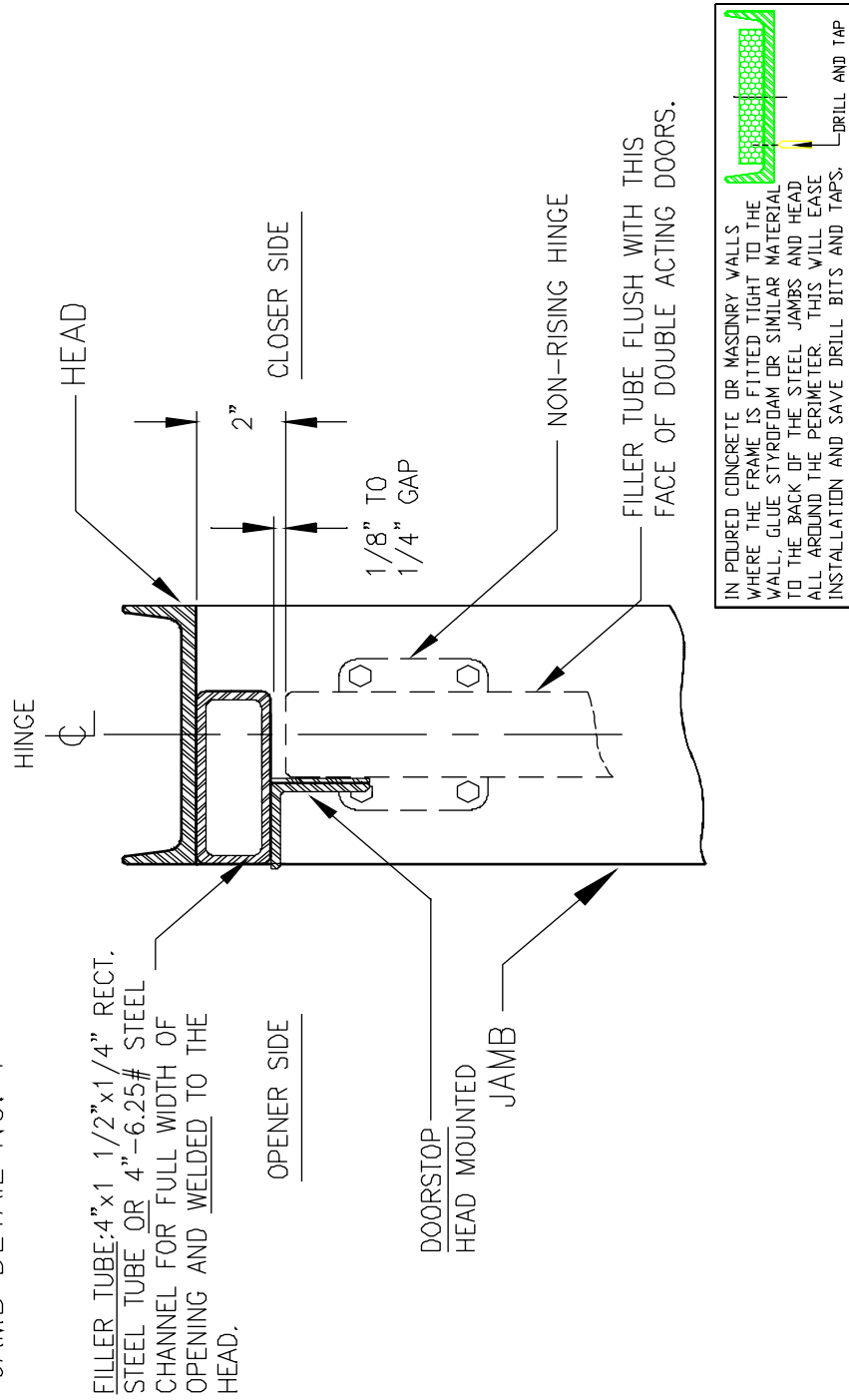

Double Acting (Center Hung) Doors: Jamb & Head Construction Detail

JAMB DETAIL NO. 2

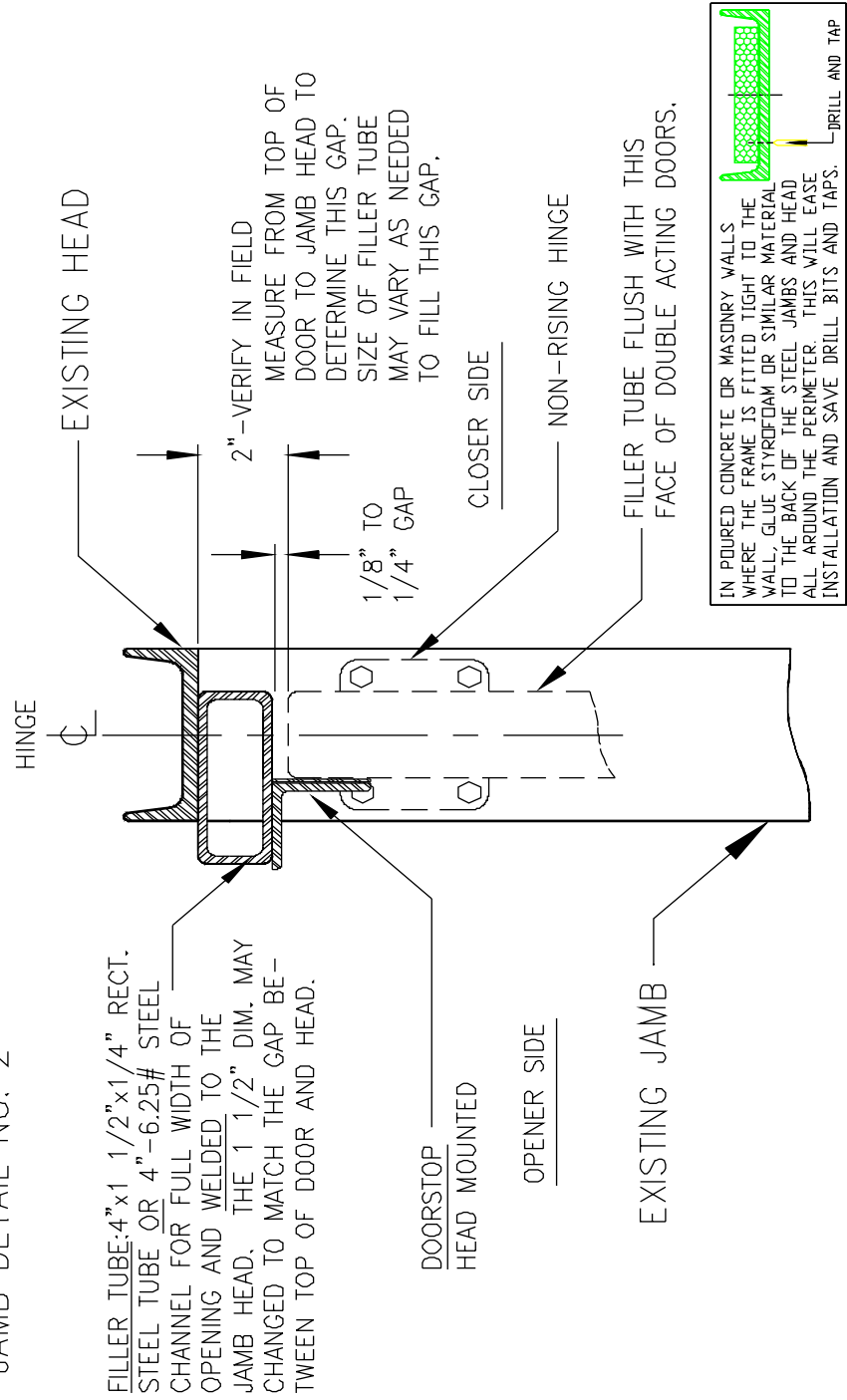

# Section 10 - Instruction Sheets / Drawings

## Double Acting (Center Hung) Doors: Jamb & Head Construction Detail

JAMB DETAIL NO. 3

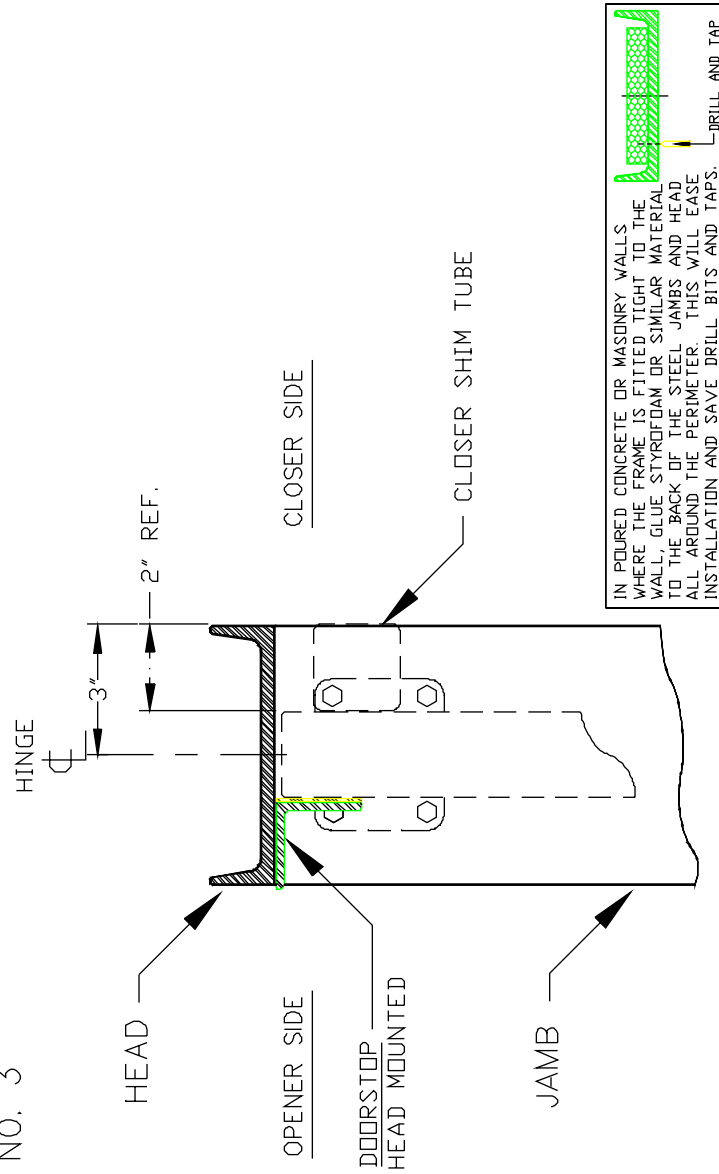

## Double Acting (Center Hung) Doors: Jamb & Head Construction Detail

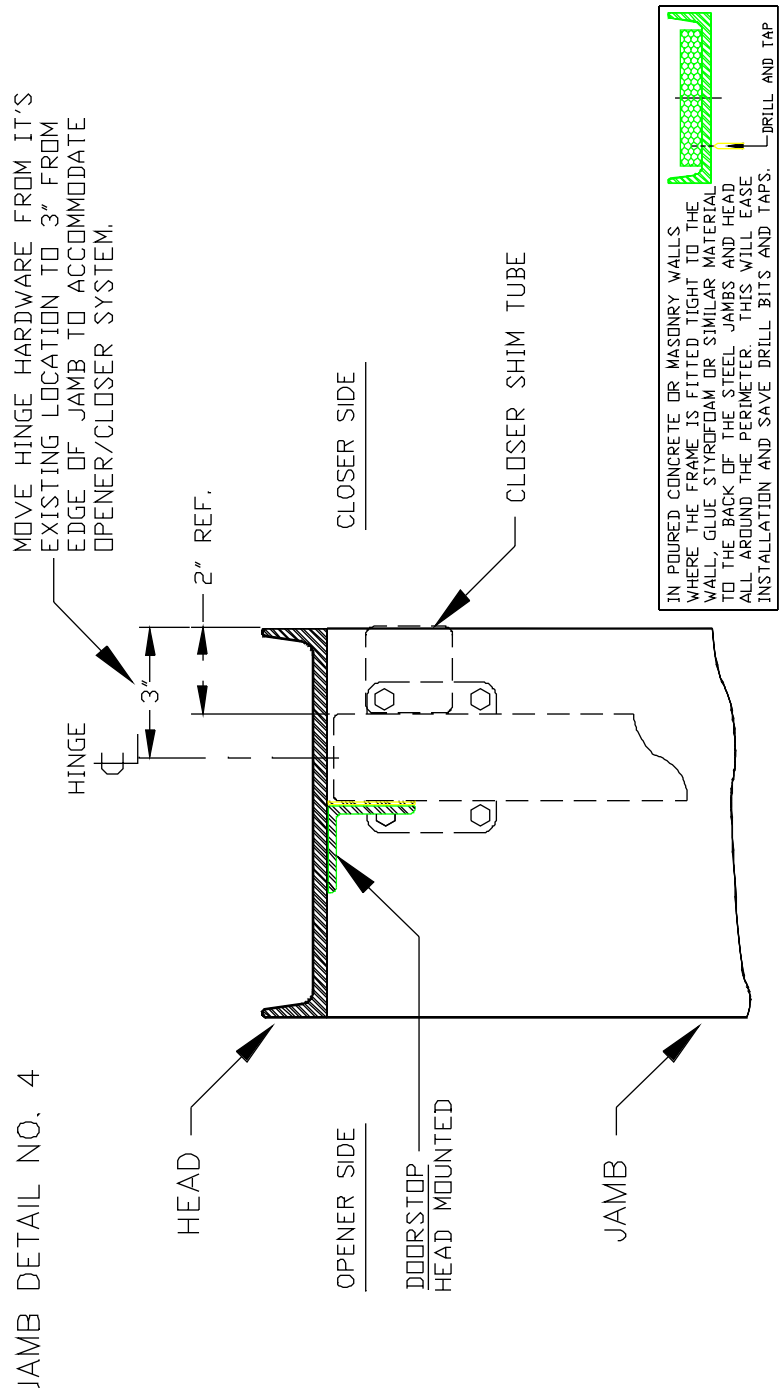

DOUBLE ACTING (CENTER HUNG ) DOORS : JAMB AND HEADER CONSTRUCTION DETAILS

JAMB DETAIL NO.5  
BI-PARTING DOORS

FILLER TUBES (2): 4"x1 1/2"x1/4" RECT. STEEL TUBE OR 4"-6.25# STEEL CHANNEL EACH TO BE ONE HALF OF THE FULL WIDTH OF THE OPENING, OFFSET FLUSH TO THE OPENER SIDE OF EACH BI-PARTING DOOR AND WELDED TO THE FRAME HEAD.

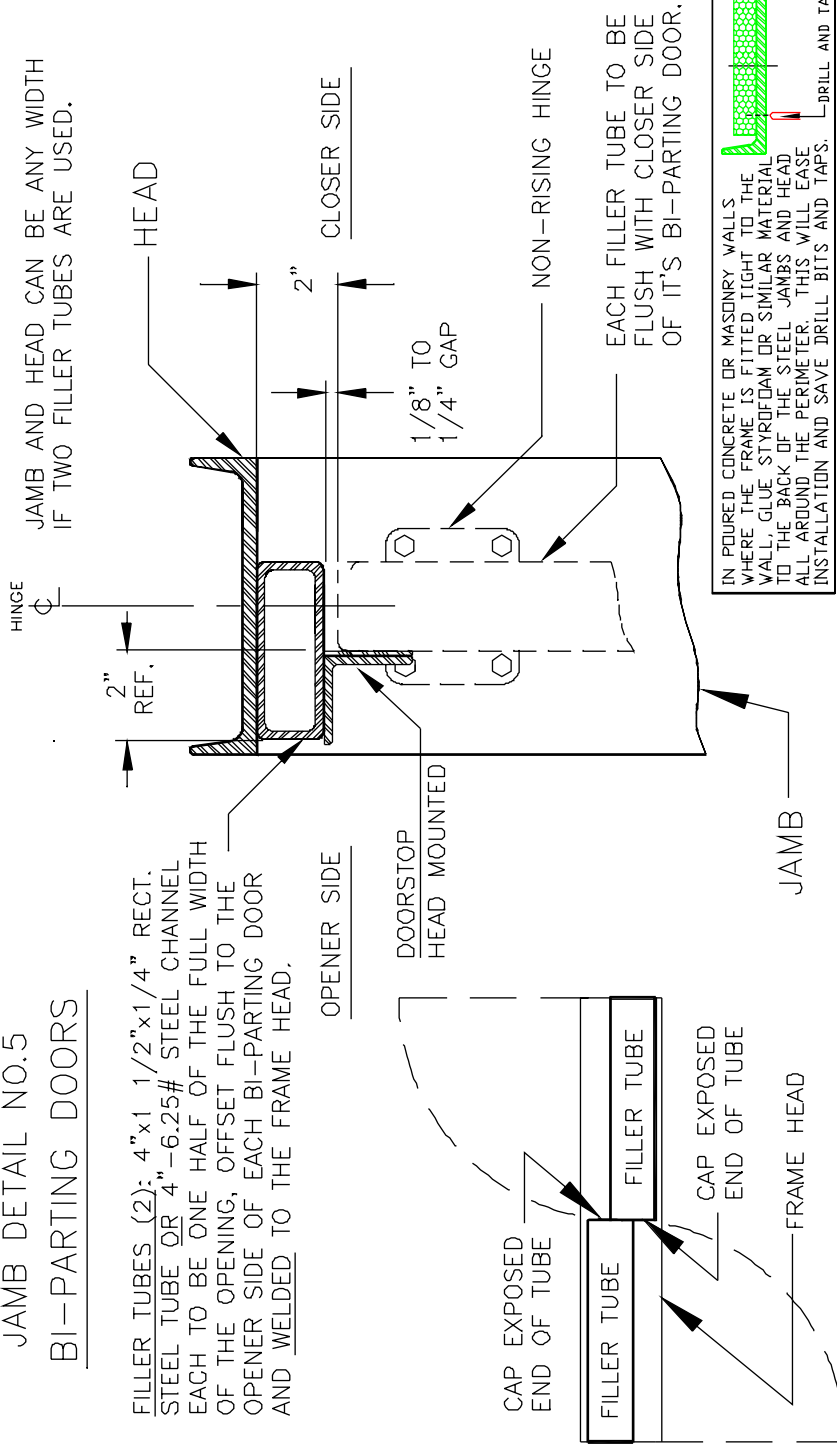

DD-9025a

JAMB DETAIL NO.6  
BI-PARTING DOORS

FRAME HEAD MUST BE 6" WIDE  
IF NO FILLER TUBE IS USED.

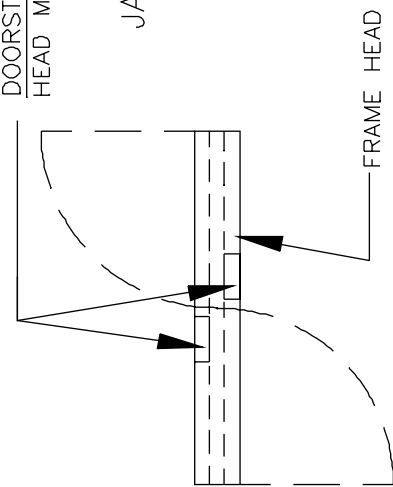
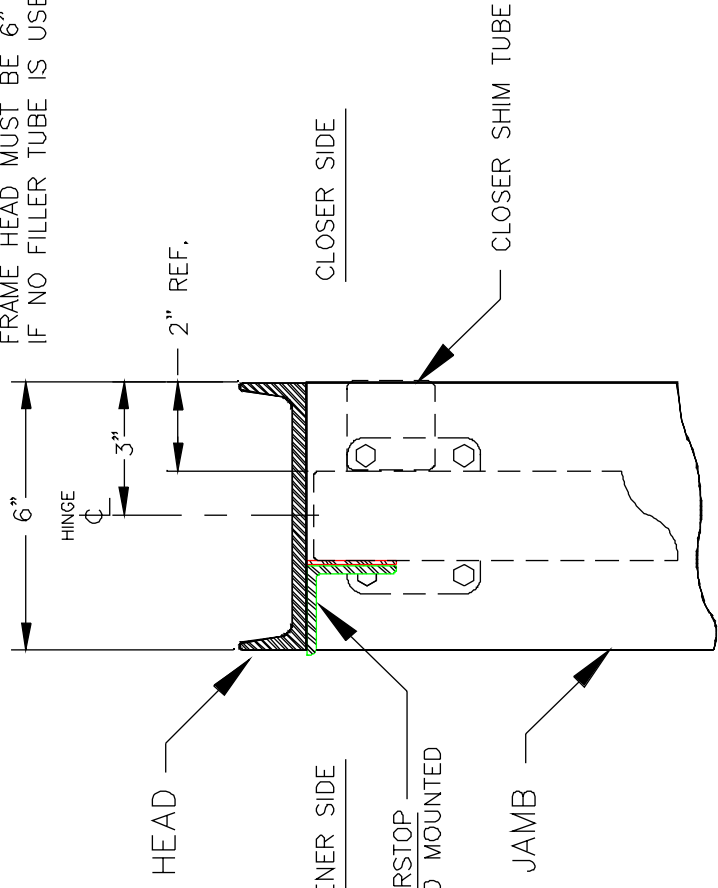

IN POURED CONCRETE OR MASONRY WALLS WHERE THE FRAME IS FITTED TIGHT TO THE WALL, GLUE STYROFOAM OR SIMILAR MATERIAL TO THE BACK OF THE STEEL JAMBS AND HEAD ALL AROUND THE PERIMETER. THIS WILL EASE INSTALLATION AND SAVE DRILL BITS AND TAPS.

DRILL AND TAP

DWG. NO. DD-9025

FLUSH DOORS IN RABBETTED JAMBS: T-BRACKET MOUNTING DETAILS

JAMB DETAIL NO.7

16 GAGE OR HEAVIER

RETROFIT

PER TEMPLATE 15043.00  
DRILL (4) 3/8" DIA. HOLES THRU  
HEAD FOR 1/4"-20 NUT SERTS.

ON VERY NARROW JAMBS,  
INSTALL NUT SERTS IN  
RECESS.

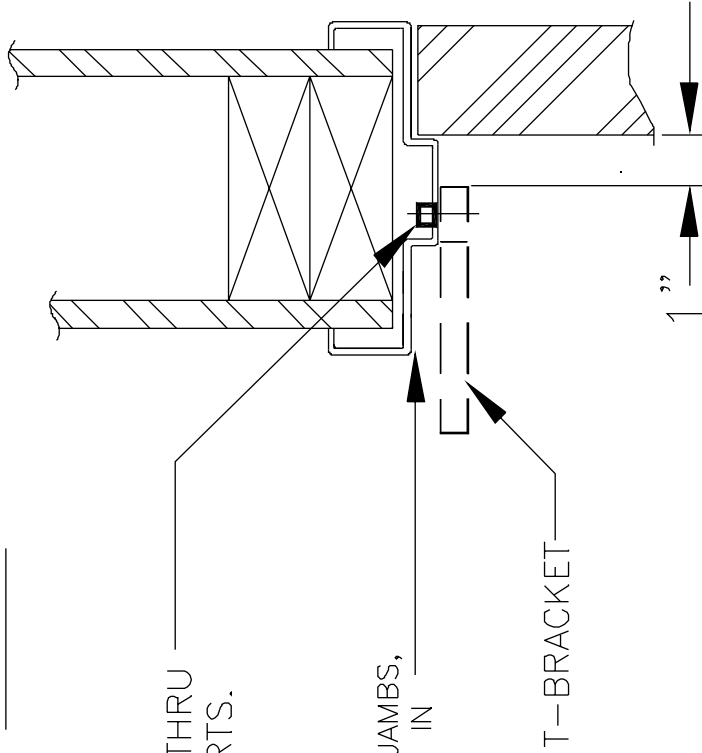
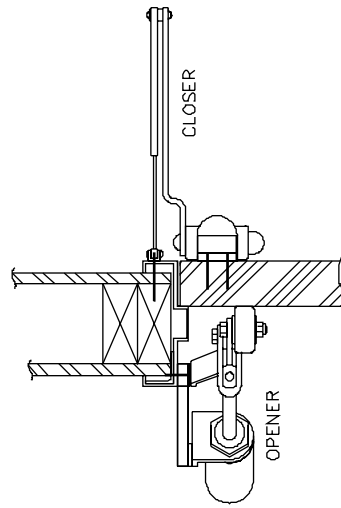

IN POURED CONCRETE OR MASONRY WALLS WHERE THE FRAME IS FITTED TIGHT TO THE WALL, GLUE STYROFOAM OR SIMILAR MATERIAL TO THE BACK OF THE STEEL JAMBS AND HEAD ALL AROUND THE PERIMETER. THIS WILL EASE INSTALLATION AND SAVE DRILL BITS AND TAPS.

DD-9028a

JAMB DETAIL NO.8  
LESS THAN 16 GAGE

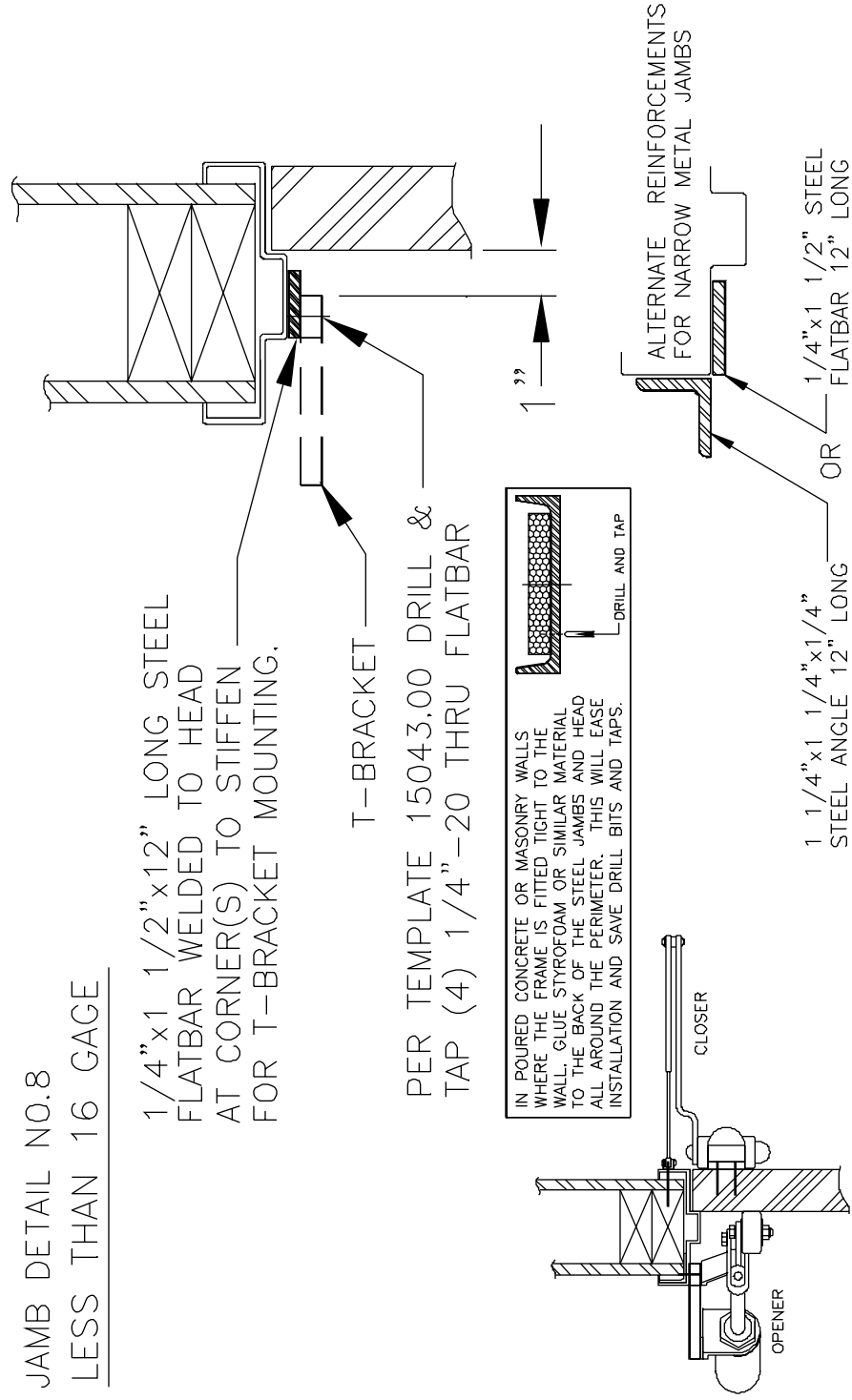

DWG. NO. DD-9028

FLUSH DOORS IN RABBETTED JAMBS: T-BRACKET MOUNTING DETAILS

NEW CONSTRUCTION

JAMB DETAIL NO.9

WELD BRACKET (RECOMMENDED FOR VERY NARROW JAMBS)

PER TEMPLATE 15043.00  
LOCATE WELD-BAR FOR T-BRACKET  
PART NUMBER DD-7020, AND  
WELD TO HEAD.

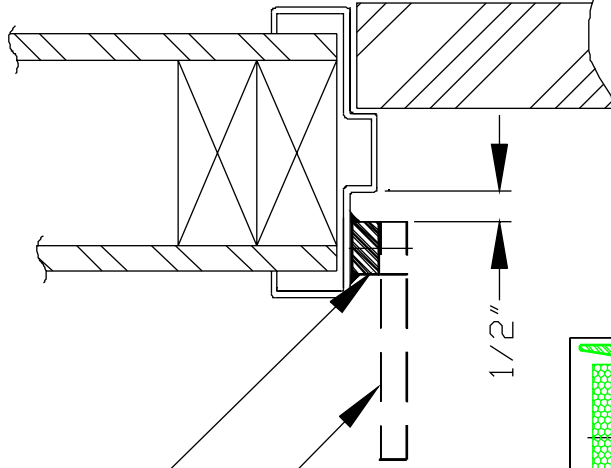

T-BRACKET

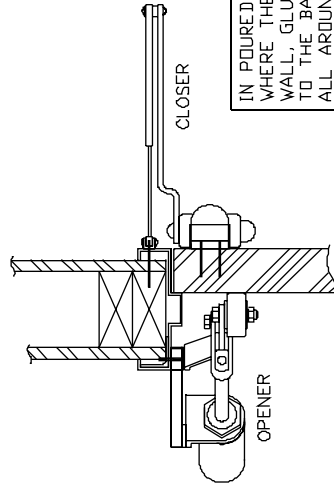

CLOSER

OPENER

IN POURED CONCRETE OR MASONRY WALLS WHERE THE FRAME IS FITTED TIGHT TO THE WALL, GLUE STYROFOAM OR SIMILAR MATERIAL TO THE BACK OF THE STEEL JAMBS AND HEAD ALL AROUND THE PERIMETER. THIS WILL EASE INSTALLATION AND SAVE DRILL BITS AND TAPS.

DRILL AND TAP

DWG. NO. DD-9029

JAMB DETAIL NO.10  
HEAD BACKING

1/4"x1 1/2"x12" LONG STEEL  
 FLATBAR WELDED INSIDE HEAD  
 AT CORNER(S) TO STIFFEN  
 FOR T-BRACKET MOUNTING.

IN POURED CONCRETE OR MASONRY WALLS  
 WHERE THE FRAME IS FITTED TIGHT TO THE  
 WALL, GLUE STYROFOAM OR SIMILAR MATERIAL  
 TO THE BACK OF THE STEEL JAMBS AND HEAD  
 ALL AROUND THE PERIMETER. THIS WILL EASE  
 INSTALLATION AND SAVE DRILL BITS AND TAPS.

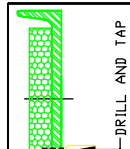

T-BRACKET

PER TEMPLATE 15043.00, DRILL  
 AND TAP <4> 1/4"-20 THRU HEAD

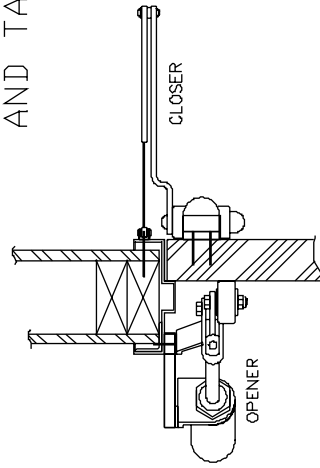

ALTERNATE REINFORCEMENT  
 FOR NARROW METAL JAMBS

1/4"x1 1/2" STEEL  
 FLATBAR 12" LONG

DWG. NO. DD-9029

## Section 10 - Instruction Sheets / Drawings

### DOORSTOP - HEAD MOUNTED for CENTER HUNG DOORS ONLY

- ① ALIGN DOORS IN THE CLOSED POSITION BY PLACING A STRAIGHTEDGE ACROSS BOTH PANELS.
- ② CENTER DOORSTOP ON CENTERLINE OF OPENING OR AT MEETING EDGES OF PANELS.
- ③ USING HOLES IN DOORSTOP AS A TEMPLATE, MARK HOLE CENTERS, AND THEN DRILL AND TAP FOR 1/4"-20 FASTENERS.
- ④ MOUNT DOORSTOP USING THE 1/4"-20 x 1" FASTENERS PROVIDED.

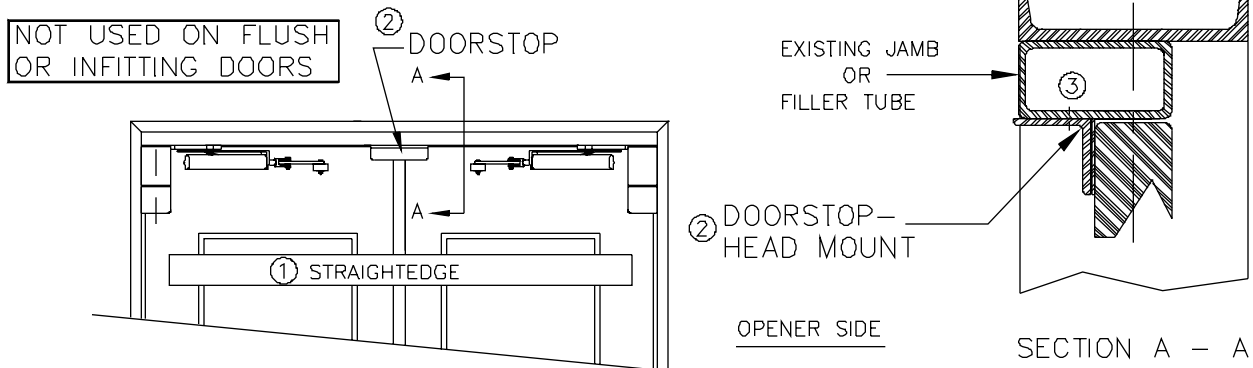

### DOORSTOPS - FLOOR MOUNTED - ALL DOORS

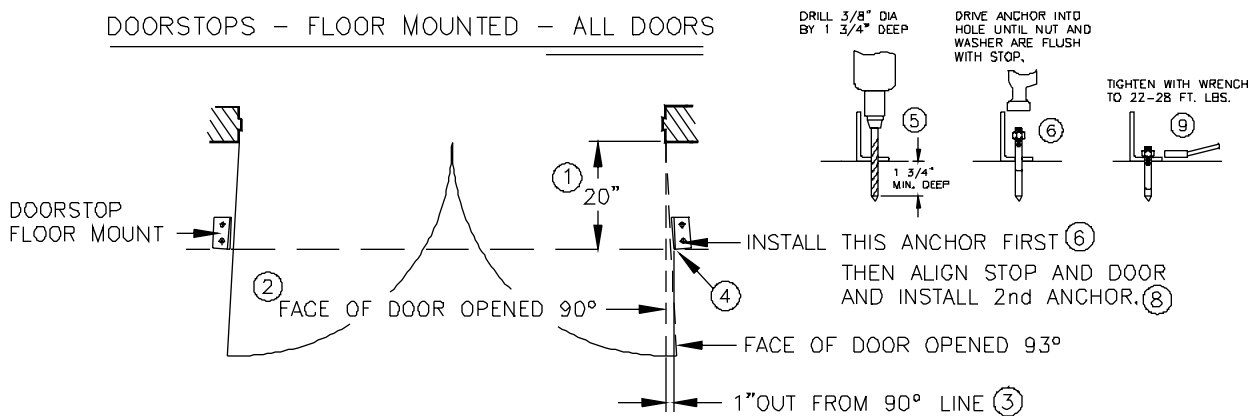

- ① MEASURE OUT FROM HINGE 20" AND STRIKE LINE PARALLEL TO WALL
- ② OPEN DOOR 90°, SET WITH CARPENTER'S SQUARE. MARK FACE OF DOOR @ 90° ON 20" LINE.
- ③ MEASURE OUT 1" ON 20" LINE FROM "FACE OF DOOR" AND MARK FOR CORNER OF STOP.
- ④ LOCATE CORNER OF DOORSTOP @ 20"-1" LINES AND MARK CLOSEST (OUTER) HOLE CENTER.
- ⑤ DRILL (1) 3/8" DIA. HOLE TO A MINIMUM DEPTH OF 1 3/4".
- ⑥ DRIVE ANCHOR INTO HOLE UNTIL NUT AND WASHER ARE FLUSH WITH STOP.
- ⑦ TIGHTEN NUT SNUG TO STOP.
- ⑧ OPEN DOOR AGAINST STOP AND ALIGN FACE OF STOP WITH FACE OF DOOR (NOW AT 93°). MARK 2nd. HOLE CENTER AND REPEAT STEPS 5 & 6.
- ⑨ TIGHTEN NUTS WITH TORQUE WRENCH TO 22-28 FT. LBS.
- ⑩ REPEAT STEPS 2 THRU 9 WITH OTHER DOOR PANEL.

## Center Hung or Flush Installation:

### OPENER/CLOSER INSTALLATION INSTRUCTIONS

#### BASIC COMPONENT ORIENTATION AND HOLE PATTERNS

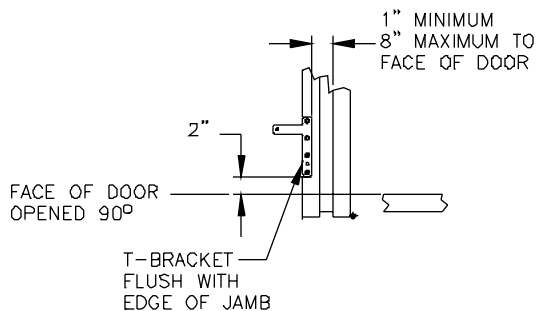
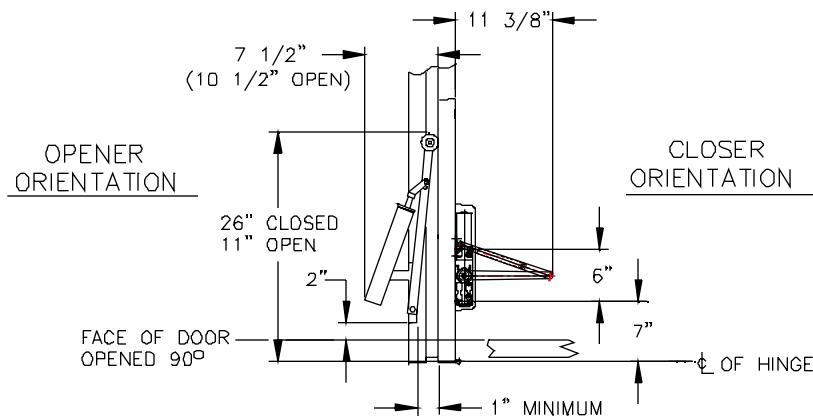
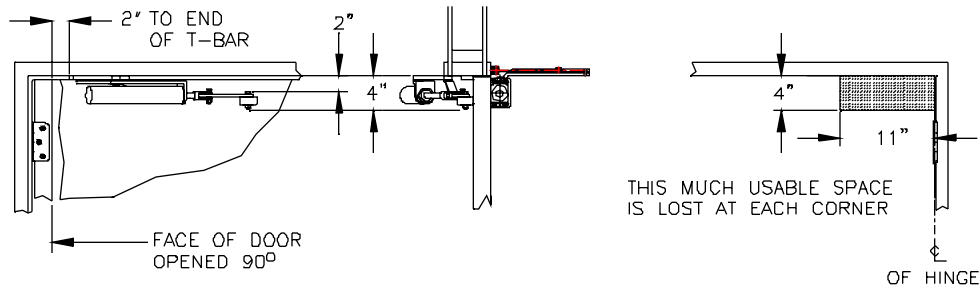

#### T-BRACKET MOUNTING LOCATION

USING THE TEMPLATE PROVIDED:  
 STEEL: DRILL AND TAP 1/4"-20  
 WOOD: DRILL 3/16" FOR #14 SCREWS  
 HOLLOW METAL JAMBS: WELD ON 1/4" ANGLE OR FLATBAR TO PROVIDE SOLID MOUNTING SURFACE.

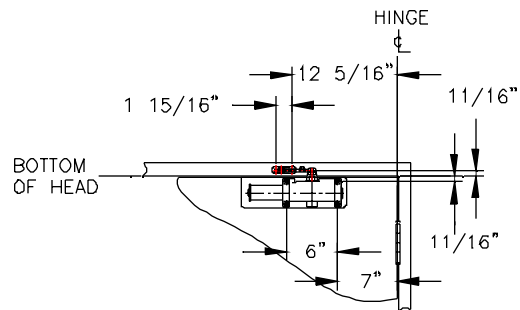

#### CLOSER MOUNTING HOLE PATTERN

USING THE TEMPLATE PROVIDED:  
 STEEL: DRILL AND TAP 1/4"-20  
 WOOD: DRILL 3/16" FOR #14 SCREWS  
 HOLLOW OR COMPOSITE: DRILL 1/2" DIA. THROUGH AND INSERT SSTL SLEEVES PER INSTRUCTIONS

Section 10 - Instruction Sheets / Drawings

INSTALLATION OF CLOSER SHIM TUBE FOR CENTER HUNG DOORS

FOR USE IF CLOSER FACE OF DOOR IS MORE THAN 1" AND LESS THAN 3" FROM FACE OF JAMB (DIM. "A").

IF DIM. "A" IS GREATER THAN 3" CONTACT FACTORY.

NEW CONSTRUCTION: MOUNT HINGES SO CENTERLINE IS 3" FROM FACE OF JAMB.

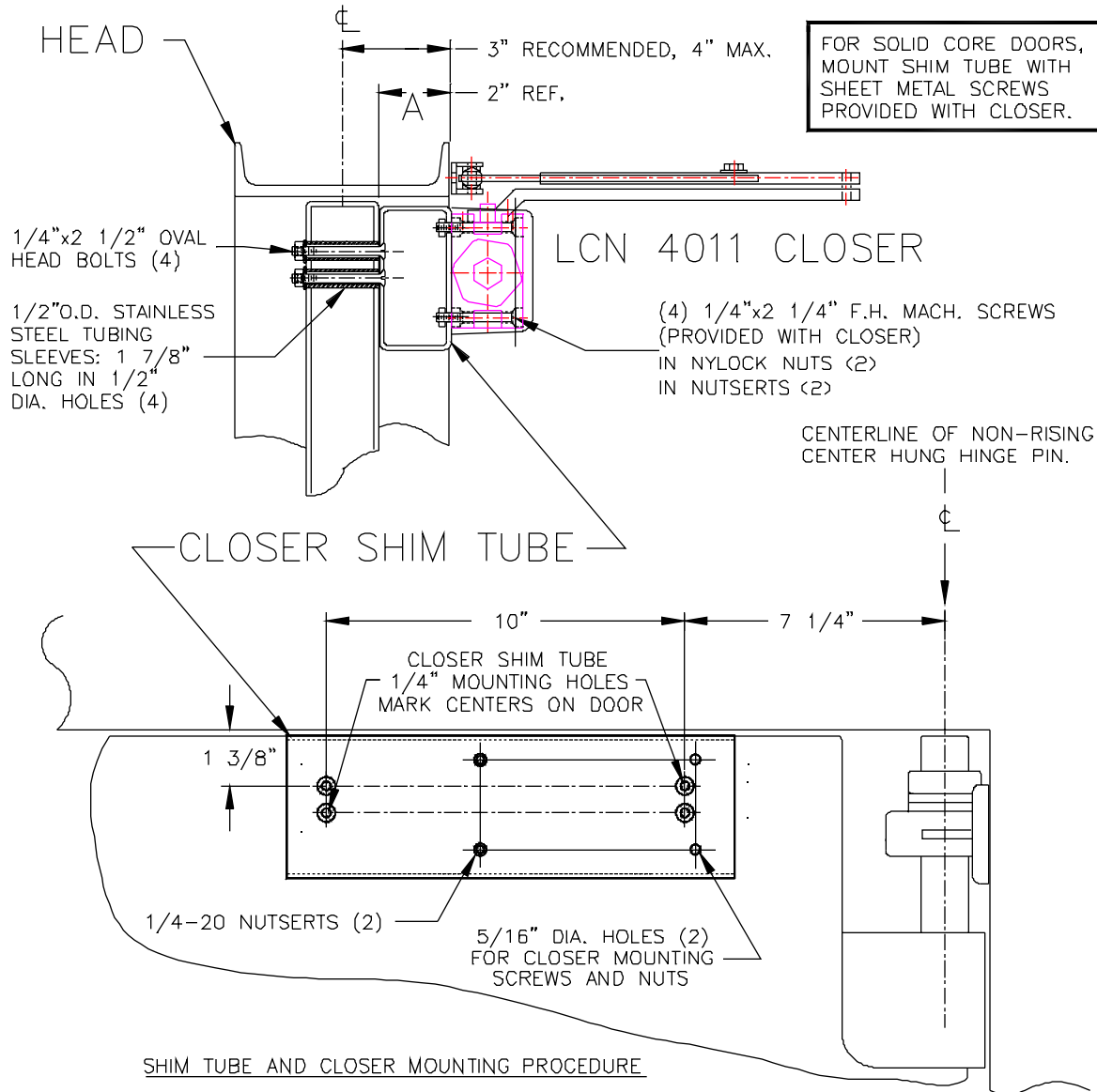

SHIM TUBE AND CLOSER MOUNTING PROCEDURE

- 1-LOCATE AND MARK (4) HOLE CENTERS AT DIMENSIONS SHOWN, USING THE CLOSER SHIM TUBE MOUNTING BOLT/SLEEVE INSTALLATION TEMPLATE.
- 2-DRILL (4) 1/2" DIA. HOLES AND INSTALL (4) STAINLESS STEEL TUBE SLEEVES.
- 3-MOUNT CLOSER SHIM TUBE WITH (4) 1/4"x2 1/2" BOLTS, NUTS AND WASHERS.
- 4-USE Closer Shim Tube Mounting Template TO LOCATE AND DRILL (2) SHOE MOUNTING HOLES IN JAMB HEAD.
- 5-MOUNT AND ADJUST DOOR CLOSER

CAM-LIFT DOUBLE ACTING DOORS CONVERTED TO NO-RISE SINGLE ACTION WITH OPENER

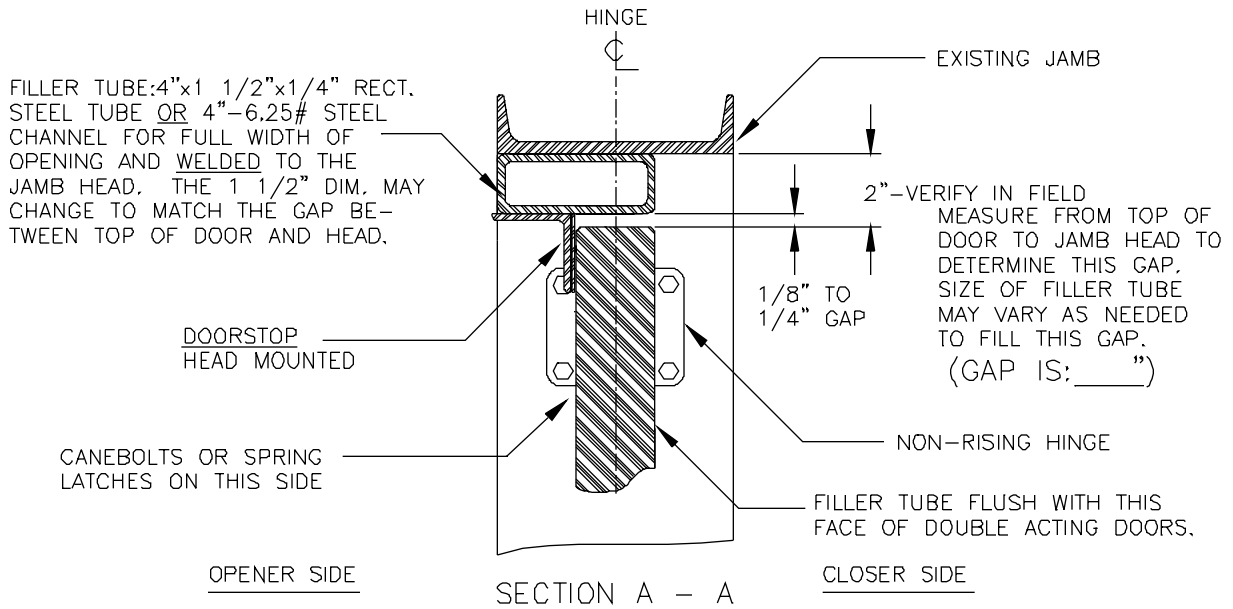
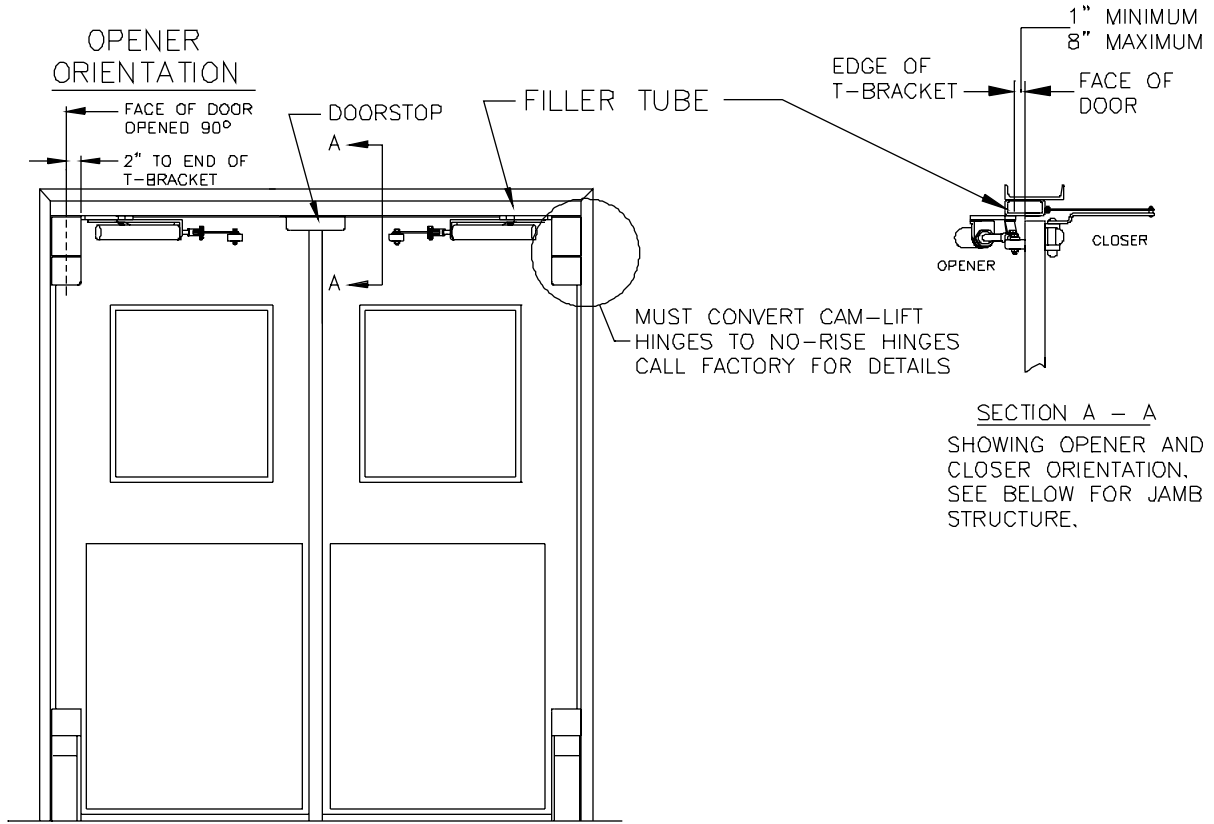

## Chase Industries "KWIK-OP" Opener Installation Details

### LCN 4011 DOOR CLOSER COMPONENT INSTALLATION

AFTER DRILLING MOUNTING HOLES WITH THE TEMPLATE PROVIDED, ORIENT AND MOUNT THE CLOSER AND THE ARM ASSEMBLY USING THE APPROPRIATE FASTENERS, THEN ADJUST CLOSER AS SHOWN IN DETAILS BELOW.

#### ARM ASSEMBLY ORIENTATION

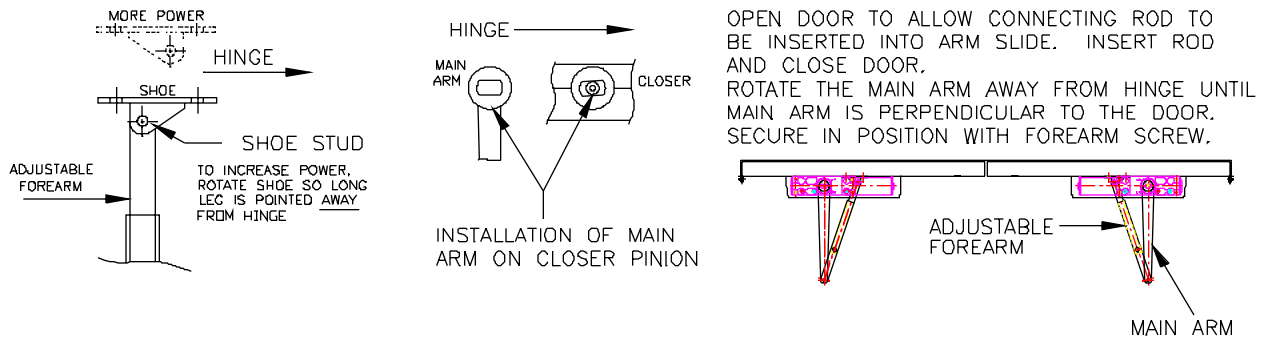

#### DOOR CLOSER ADJUSTMENTS

① THIS ADJUSTMENT IS CRITICAL FOR PROPER DOOR FUNCTION

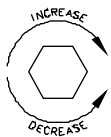

**BACKCHECK CUSHIONING**  
(ADJUSTMENT SCREW ON TOP AND FARTHEST FROM HINGE)  
CONTROLS "CUSHION" AT END OF OPENING CYCLE. ADJUST WITH 3/32" HEX WRENCH

③ ADJUST WITH 3/32" HEX WRENCH SWEEP SPEED LATCH CHECK

IN MOST INSTALLATIONS ① IS THE ONLY ADJUSTMENT REQUIRED. MAKE ALL ADJUSTMENTS ONE AT A TIME.

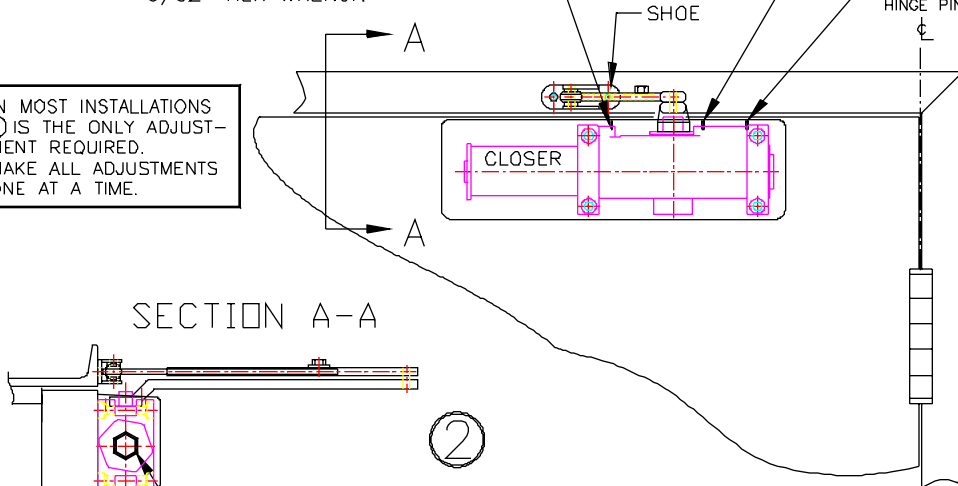

#### SECTION A-A

② OPENING/CLOSING POWER ADJUSTMENT  
TURN CLOCKWISE TO INCREASE POWER  
9 TURNS MAX, USE 1/4-1/2 TURN INCREMENTS  
SOME RESISTANCE IS REQUIRED FOR PROPER CLOSER OPERATION. DO NOT DECREASE FACTORY SETTING TO ANY GREAT DEGREE.

REFER TO LCN "SMOOTHEE" CLOSER INSTALLATION SHEET, DOOR MOUNTING, 101" TO 120" OPENING.

ANY QUESTIONS? CALL 1-800-305-6736

DWG. NO. DD-9061A